

1 Solution Overview

1.1 ABSTRACT

TNETW1350/A-based WLAN subsystems (WLS) are intended for inclusion in larger systems that already contain non-volatile storage (NVS). Because of this, NVS via an EEPROM is not necessary and not included in TNETW1350/A-based WLSs. In addition, the TNETW1350/A, by design, does not support a serial EEPROM interface. However, unique NVS data for each TNETW1350/A-based WLS, such as calibration parameters, MAC address, etc., is still required. This application note describes how to generate and store this unique NVS data, how to match specific NVS data files with specific TNETW1350/A-based WLSs, and how to transfer this NVS data to the NVS of the complete RG system. This is an EEPROMless solution, as all of these operations are accomplished without a local EEPROM in the WLS.

1.2 Assumptions

This EEPROMless solution presented in this application note assumes the following:

- A residential gateway motherboard and a WLAN subsystem (WLS) daughterboard make up a complete residential gateway (RG) system.
- The two boards are manufactured separately before being assembled into the complete RG system.
- The WLS is calibrated during its separate manufacturing process.
- The WLS EEPROM map is referred to as the NVS data file.
- The NVS device (flash) is on the RG motherboard.

1.3 Solution Summary

The EEPROMless solution consists of two main parts: the WLS manufacturing test process and the RG manufacturing process. During the **WLS manufacturing test process**, the WLS must be calibrated and the NVS data must be saved to an external binary file. Each unique binary file will be identified with the correct WLS by using the DIE_ID register value of the TNETW1350/A – this DIE_ID value will be part of the binary file name.

Note: The DIE_ID register is programmed with a unique 64-bit value (16 Hex characters) for each TNETW1350/A chip during manufacturing.

During the **RG manufacturing process**, the correct NVS data file from the WLS manufacturer must be transferred to the NVS of the complete RG system. This will be accomplished during the first boot by means of a TFTP server/client model, in which the server runs on the test PC and the client is part of the APDK running on the complete RG system. The DIE_ID of the TNETW1350/A will be read, and the TFTP client will automatically download the correct NVS data file from the server (which has access to

the NVS data files). The NVS data file will be validated and stored to a location in the complete RG system NVS. Subsequent boots will not go through this file transfer process, but will load the NVS data directly from the complete RG system NVS.

Note: The WLS NVS data file will include the DIE_ID register value for verification purposes.

WLS Manufacturing Test Process Summary:

1. Boot the WLS and test system.
2. Calibrate.
3. Save the NVS data file with the proper file name.
4. Deliver the NVS data file to the RG manufacturer in a mutually agreed upon fashion.

RG Manufacturing Process Summary:

1. Ensure the test PC has a TFTP server running with access to NVS data files from the WLS manufacturer.
2. Boot the complete RG system.

The APDK automatically downloads the correct NVS data file to the complete RG system NVS, and then loads the NVS data to the TNETW1350/A memory.

Note: Subsequent boots will not go through this file transfer process, but will load the NVS data directly from the complete RG system NVS.

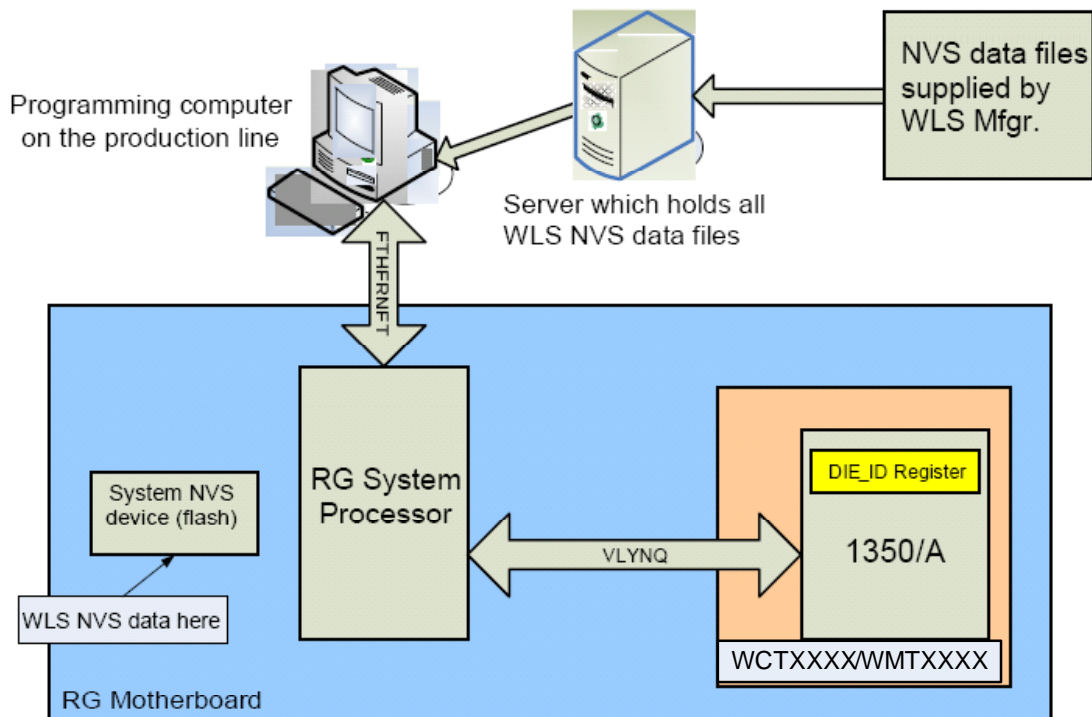

2 Design Applications

The TNETW1350A WLS-VQ-HP reference design is an extended-range Wireless LAN subsystem that supports IEEE 802.11b and 802.11g WLAN standards. WCTXXXX/WMTXXXX is referred to as a wireless LAN subsystem (WLS) because it is intended for inclusion in a larger system to enable a complete residential gateway (RG) solution.

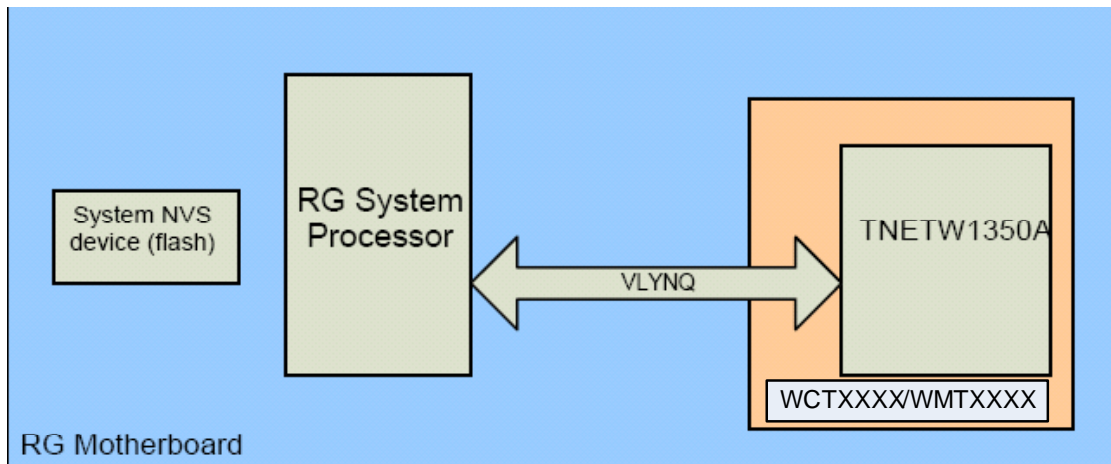

Federal Communication Commission Interference Statement

This equipment has been tested and found to comply with the limits for a Class B digital device, pursuant to Part 15 of the FCC Rules. These limits are designed to provide reasonable protection against harmful interference in a residential installation. This equipment generates, uses and can radiate radio frequency energy and, if not installed and used in accordance with the instructions, may cause harmful interference to radio communications. However, there is no guarantee that interference will not occur in a particular installation. If this equipment does cause harmful interference to radio or television reception, which can be determined by turning the equipment off and on, the user is encouraged to try to correct the interference by one of the following measures:

- Reorient or relocate the receiving antenna.
- Increase the separation between the equipment and receiver.
- Connect the equipment into an outlet on a circuit different from that to which the receiver is connected.
- Consult the dealer or an experienced radio/TV technician for help.

This device complies with Part 15 of the FCC Rules. Operation is subject to the following two conditions: (1) This device may not cause harmful interference, and (2) this device must accept any interference received, including interference that may cause undesired operation.

FCC Caution: Any changes or modifications not expressly approved by the party responsible for compliance could void the user's authority to operate this equipment.

This transmitter must not be co-located or operating in conjunction with any other antenna or transmitter.

IMPORTANT NOTE:

FCC Radiation Exposure Statement:

This equipment complies with FCC radiation exposure limits set forth for an uncontrolled environment. This equipment should be installed and operated with minimum distance 20cm between the radiator & your body.

This transmitter must not be co-located or operating in conjunction with any other antenna or transmitter.

This device is intended only for OEM integrators under the following conditions:

- 1) The antenna must be installed such that 20 cm is maintained between the antenna and users, and
- 2) The transmitter module may not be co-located with any other transmitter or antenna.
As long as 2 conditions above are met, further transmitter test will not be required. However, the OEM integrator is still responsible for testing their end-product for any additional compliance requirements required with this module installed (for example, digital device emissions, PC peripheral requirements, etc.).

IMPORTANT NOTE: In the event that these conditions can not be met (for example certain laptop configurations or co-location with another transmitter), then the FCC authorization is no longer considered valid and the FCC ID can not be used on the final product. In these circumstances, the OEM integrator will be responsible for re-evaluating the end product (including the transmitter) and obtaining a separate FCC authorization.

End Product Labeling

This transmitter module is authorized only for use in device where the antenna may be installed such that 20 cm may be maintained between the antenna and users. The final end product must be labeled in a visible area with the following: “Contains TX FCC ID: MQ4WMT0583”.

Manual Information That Must be Included

The users manual for OEM integrators must include the following information in a prominent location “ IMPORTANT NOTE: To comply with FCC RF exposure compliance requirements, the antenna used for this transmitter must be installed to provide a separation distance of at least 20cm from all persons and must not be co-located or operating in conjunction with any other antenna or transmitter.