



MediaTek LinkIt™ Smart 7688 User Manual

Version: 0.9 Beta

Release date: October 2015

Specifications are subject to change without notice.

© 2015, 2016 MediaTek Inc.

This document contains information that is proprietary to MediaTek Inc.
Unauthorized reproduction of this information in whole or in part is strictly prohibited.

Document Revision History

Revision	Date	Description
0.9	October 2015	Close Beta

1. Introduction

LinkIt Smart 7688 development platform is an IoT development platform by MediaTek Labs. It enables you to design and create Wi-Fi connected devices for the home, the office and Cloud applications.

1.1. What is MediaTek LinkIt Smart 7688 Development Platform

The LinkIt Smart 7688 is an open development platform based on Linux distribution [OpenWrt](#). It offers two development boards which come in two hardware configurations: LinkIt Smart 7688 (MPU only) and LinkIt Smart 7688 Duo (MPU and MCU). The LinkIt Smart 7688 is powered by MediaTek's MT7688 SOC and supports Windows, Mac OS X and Linux.

LinkIt Smart 7688 Duo has the same MPU in addition to a MCU which is powered by ATmega32U4. It supports Arduino and high level programming language such as Python, Node.js and C so that you can create your own scripts for rich peripheral interactions.

The LinkIt Smart 7688 development platform supports built-in Wi-Fi, Ethernet, USB host and Micro-SD card slot as well as serial port for Linux console.

1.2. MediaTek MT7688AN Chip Specification Summary

Specifications of the MT7688AN SOC are shown in below.

MT7688AN SOC Specifications	
CPU	MIPS24KEc (580 MHz)
Total DMIPs	580 x 1.6 DMIPs
I-Cache, D-Cache	64 KB, 32 KB
L2 Cache	N/A
Memory	<ul style="list-style-type: none"> • DDR1/DDR2 • 16 bits • Max. 2 Gb, 193 MHz
SPI Flash	<ul style="list-style-type: none"> • 3B addr mode (max 128Mbit) • 4B addr mode (max 512Mbit)
SD	SD-XC (class 10)
RF	1T1R 802.11n 2.4GHz
Package	DR-QFN156-12 mm x 12 mm
<i>Interface</i>	<i>Count</i>
PCIe	1
USB 2.0	1

<i>Interface</i>	<i>Count</i>
Fast Ethernet Switch	5
I2S	1
PCM	1
PWM	4
SPI	1
I2C	1
UART(Lite)	3
JTAG	1

Table 1 MT7688AN SOC Specification

1.3. LinkIt Smart 7688

LinkIt Smart 7688 is one of the most highly integrated and compact hardware development boards available for IoT prototyping.

1.3.1. Key Features

LinkIt Smart 7688's key features include the following:

- Wi-Fi 802.11 b/g/n (2.4G)
- Pin-out for GPIO, I2C, I2S, SPI, UART, PWM and Ethernet Port
- 580 MHz MIPS CPU
- 32MB flash and 128MB DDR2 RAM
- USB host
- Micro SD slot

LinkIt Smart 7688 is shown in Figure 1.

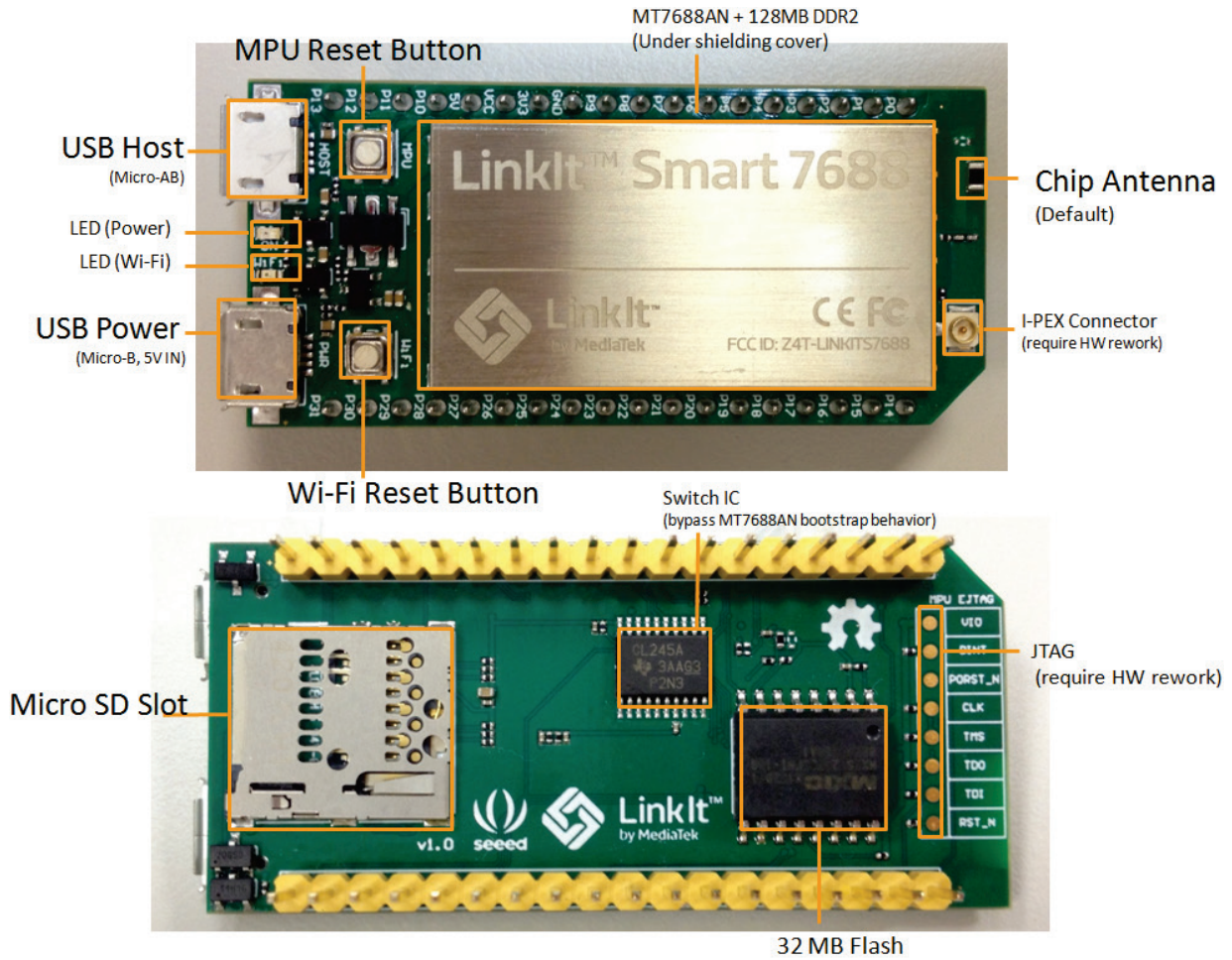

Figure 1 LinkIt Smart 7688 development board (MPU only)

1.3.2. Buttons

The buttons description on LinkIt Smart 7688 and how to use them are described in Table 2.

Scenario	Button	Action
Resets the MPU	MPU Reset Button	One Press
Resets Wi-Fi to AP mode	Wi-Fi Reset Button (After system is boot up)	Press for at least 5 seconds and release
Factory resets and enters AP mode WARNING: Restore to default setting and all user data will be	Wi-Fi Reset Button (After system is boot up)	Press for at least 20 seconds and release

Scenario	Button	Action
removed from the device		
Upgrades firmware from a USB drive	Wi-Fi Reset Button (At power up)	Press for at least 5 seconds and release
Upgrades boot loader from a USB drive WARNING: Restore to default setting and all user data will be removed from the device	Wi-Fi Reset Button (At power up)	Press for at least 20 seconds and release

Table 2 LinkIt Smart 7688 Development board buttons

1.3.3. LEDs

- Power

Power LED turns solid on in green color when power is supplied.

- Wi-Fi

Wi-Fi LED are in orange color and their blink pattern is described in Table 3. For more information on Access Point and Station mode, please see 2.3, "Network Environment".

Mode	Status	LED blink pattern
AP Mode	With client device	3 blinks in 1 second and pause for 0.5 seconds (cycle repeats)
	Without client device	Off
Station Mode	Disconnected	Off
	Connecting	2 blinks in 1 second
	Data transmission	Blinking based on the transmitted data package

Table 3 Wi-Fi LED blink pattern in LinkIt Smart 7688 HDK

1.3.4. Antenna

There are two types of antenna support available on LinkIt Smart 7688 development board:

- 1) Built in Wi-Fi chip antenna and it is the default antenna.
- 2) I-PEX connector for external antenna.

To enable the connector, you'll need to remove the resistor R233 located on the top left corner of the I-PEX connector, as circled in Figure 2.

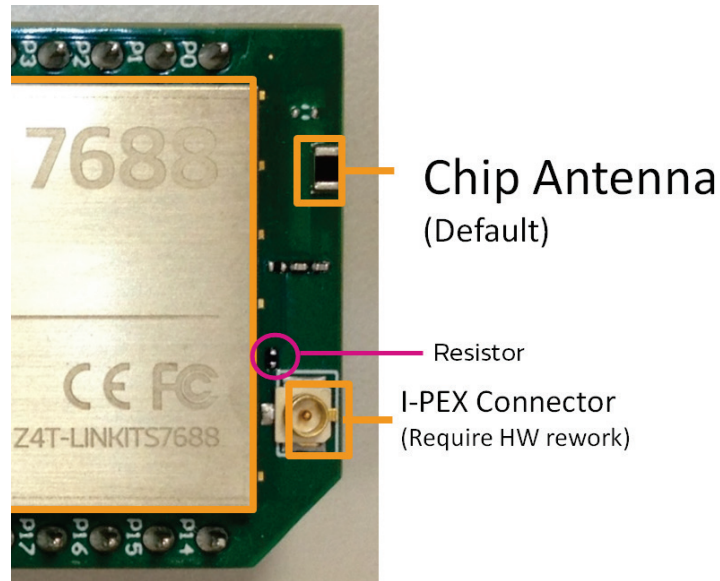

Figure 2 Removing the resistor to enable I-PEX connector

1.3.5. USB Host

LinkIt Smart 7688 provides USB host capability which enables it to connect to different USB devices such as webcams, USB drives, keyboards, joysticks and more. The connector used is USB Micro-AB type.

1.3.6. USB Power

The USB cable provides 5V steady power source to LinkIt Smart 7688 development boards. When you add peripheral devices such as SD card, USB drive or other USB devices to the development board, additional power may be consumed. Please use a proper USB cable to reduce power loss. If your peripheral device consumes power heavily, it's better to use an external power source for it.

The approximate power consumption of various devices used on LinkIt Smart 7688 is described in below.

Scenario		Approximate Power Consumption
To establish Wi-Fi connection	Peak	475.3 mA
	Average	255.6 mA
Device boot up	Peak	605.4 mA

Scenario		Approximate Power Consumption
	Average	195.1 mA
Downloading file to a SD Card via Wi-Fi	Peak	540.4 mA
	Average	275.8 mA
Downloading a file to a USB Drive via Wi-Fi	Peak	569.5 mA
	Average	304.9 mA
Downloading a file to flash via Wi-Fi	Peak	522.4 mA
	Average	271.3 mA

Table 4 Peripherals Power Consumption

1.3.7. Accessories

LinkIt Smart 7688’s standard package comes with the development board only. You will need additional accessories for different purposes as described below.

- 1) **USB Power Cable (Required):** You’ll need a USB type A to Micro-B plug cable to power the LinkIt Smart 7688 development board from a PC or other USB powered source.
- 2) **Micro USB OTG (On-The-Go) or Host Cable (Optional):** Use this OTG cable to access Type A USB devices such as USB drive or USB camera and more as shown in Figure 3.



Figure 3 USB OTG cable

- 3) **USB-UART Cable (Optional):** Use this cable to communicate to Linux console.
- 4) **Micro SD Card (Optional):** Use Micro SD card for extra storage space for applications and data.
- 5) **USB Drive (Optional):** For extra storage. You can also use it to store bootloader and firmware to upgrade LinkIt Smart 7688.

1.3.8. Breakout Board (TBD)

1.3.9. JTAG

You can use JTAG interface to debug MT7688AN. To access JTAG interface, you will need to unsolder resistor R95 and solder it to resistor R3 on the 7688 development board. After you've moved the resistor and reboot the device you'll activate JTAG function. The steps are:

- 1) Find a group of resistors on the bottom side of LinkIt Smart 7688 (top-right view) as circled in below.

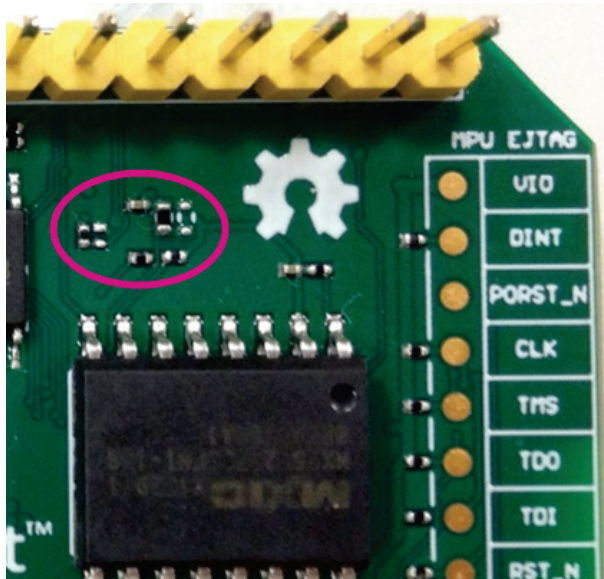

Figure 4 JTAG resistors on LinkIt Smart 7688 Bottom view

- 2) Next, you will move a resistor by unsoldering and soldering it to a lower position as shown in below, after you've finished moving the resistor, restart the device and you should be able to activate JTAG function.

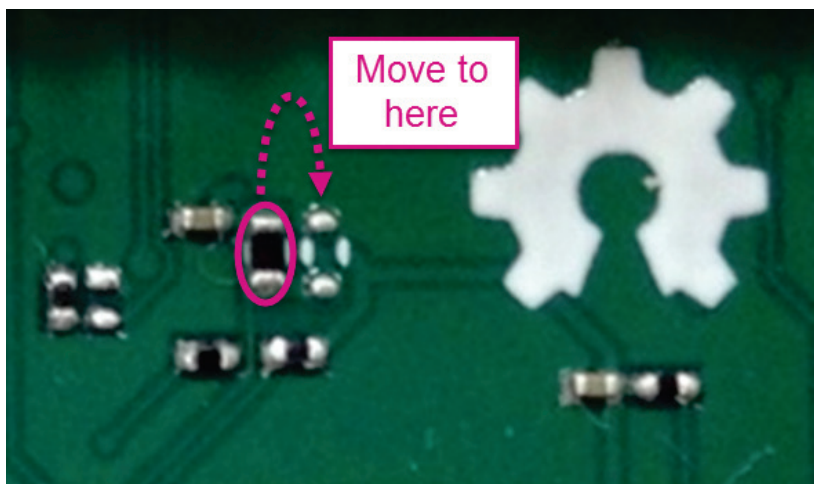

Figure 5 Moving a resistor to access JTAG mode

1.3.10. Specifications

The key specifications of LinkIt Smart 7688 development boards are shown in Table 5.

Category	Feature	LinkIt Smart 7688 Spec.
MPU	Chipset	MT7688AN
	Core	MIPS24KEc
	Clock speed	580MHz
	Working voltage	3.3V
PCB Size	Dimensions	55.7 x 26 mm
Memory	Flash	32MB
	RAM	128MB DDR2
Power Source	USB Power	5V (USB Micro-B)
	VCC	3.3V (Pin Breakout)
GPIO	Pin Count	22 (MT7688AN)
	Voltage	3.3v
PWM	Pin Count	4 (MT7688AN)
	Voltage	3.3v
	Max. Resolution	7 bits (customizable)
	Maximum Frequency@Resolution	100kHz@1-bit 50kHz@2-bit 25kHz@3-bit 12.5kHz@4-bit 6.25kHz@5-bit 3.125kHz@6-bit 1.5625kHz@7-bit (Standard mode) 40MHz@1-bit 20MHz@2-bit 10MHz@3-bit 5MHz@4-bit 2.5MHz@5-bit 1.25Mhz@6-bit 625kHz@7-bit (Fast mode)
External Interrupts	Pin Count	22 (MT7688AN)
SPI	Set count	1 (MT7688AN)

Category	Feature	LinkIt Smart 7688 Spec.
	Pin numbers	<ul style="list-style-type: none"> P22, P23, P24 (Shared with on-board flash) P25
	Max. Speed	25 MHz
SPI Slave	Set count	1 (MT7688AN)
	Pin numbers	P28, P29, P30, P31
	Max. Speed	25 MHz
I2S	Set Count	1 (MT7688AN)
	Pin numbers	P10, P11, P12, P13
I2C	Set Count	1
	Pin numbers	P20, P21
	Speed	120K/400K
UART (Lite)	Set Count	3 (MT7688AN)
	Pin numbers	P8, P9, P16, P17, P18, P19
	Max. Speed	115,200 bps
USB Host	Pin Count	1 (MT7688AN)
	Pin numbers	P6, P7
	Connector type	Micro-AB
Communication	Wi-Fi	1T1R 802.11 b/g/n (2.4G)
	Ethernet	1-port 10/100 FE PHY
	Pin numbers	P2, P3, P4, P5
User Storage	SD Card	Micro SD SDXC

Table 5 LinkIt Smart 7688 development boards specifications

1.3.11. Pin-out Diagram

This pin-out diagram helps you to map the pins on LinkIt Smart 7688 development board to the peripheral devices you want to attach through interfaces such as GPIO, PWM, I2C, I2S, SPI, UART and more. The available pins for LinkIt Smart 7688 HDK are illustrated in the next page. You can also download it from MediaTek Labs website.

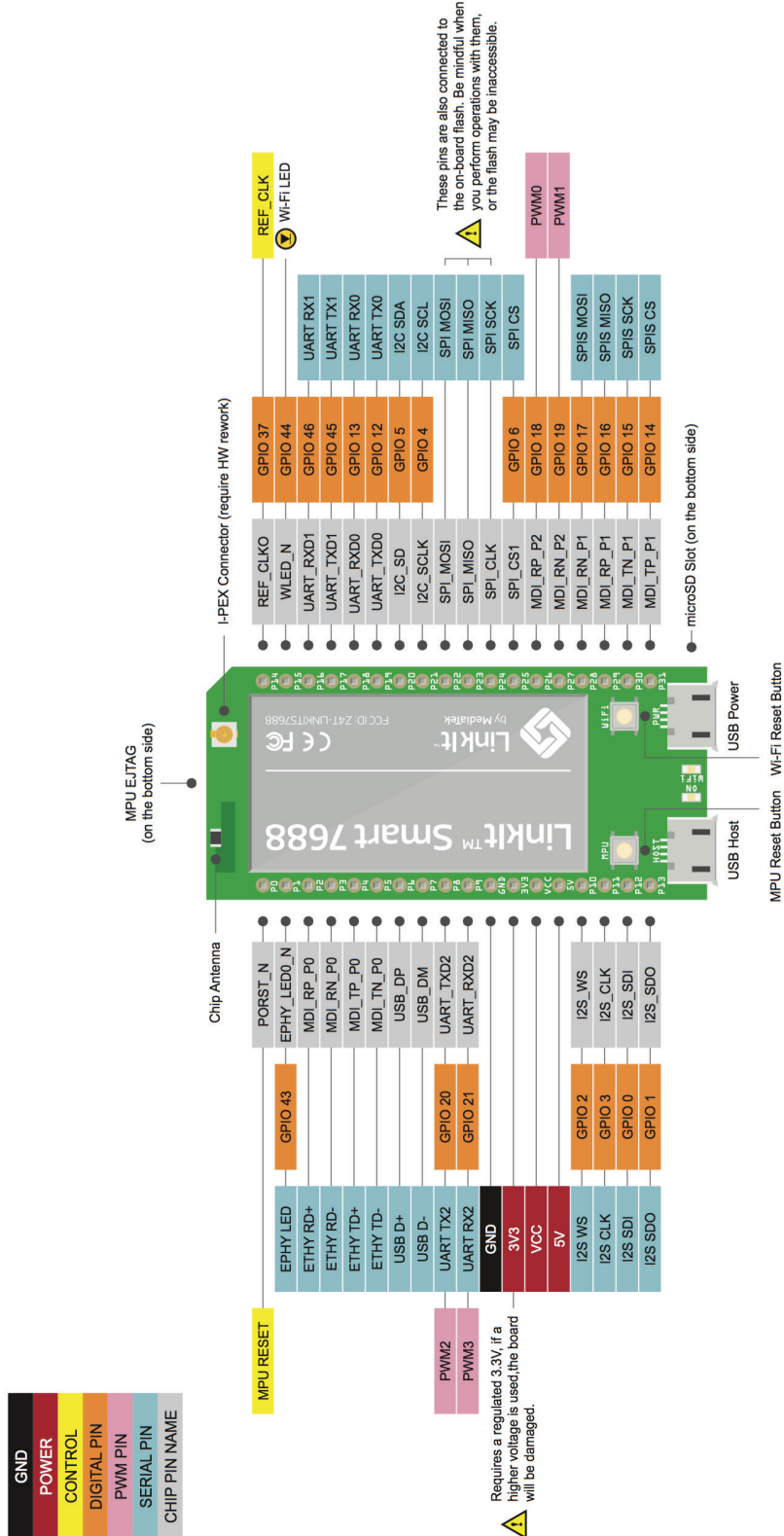

1.4. LinkIt Smart 7688 Duo

LinkIt Smart 7688 Duo is powered by the same MT7688AN SOC as LinkIt Smart 7688, but adds an extra ATmega32U4 on the development board. This supports additional features including Analog I/O support and Arduino IDE support. The board's functionality thus becomes a combination of both chipsets: Wi-Fi and Ethernet support through OpenWRT Linux on MT7688AN SOC, and various kinds of peripheral support through Arduino on ATmega32U4 microcontroller.

1.4.1. Key Features

Linkit Smart 7688 Duo's key features include the following:

- Wi-Fi 1T1R 802.11 b/g/n (2.4G)
- Pin-out for GPIO, I2C, I2S, SPI, SPIS, UART, PWM and Ethernet Port
- 580 MHz MIPS CPU
- 32MB flash and 128MB DDR2 RAM
- Built-in USB host and Micro SD slot
- Arduino support (ATmega32U4)

LinkIt Smart 7688 Duo is shown in Figure 6.

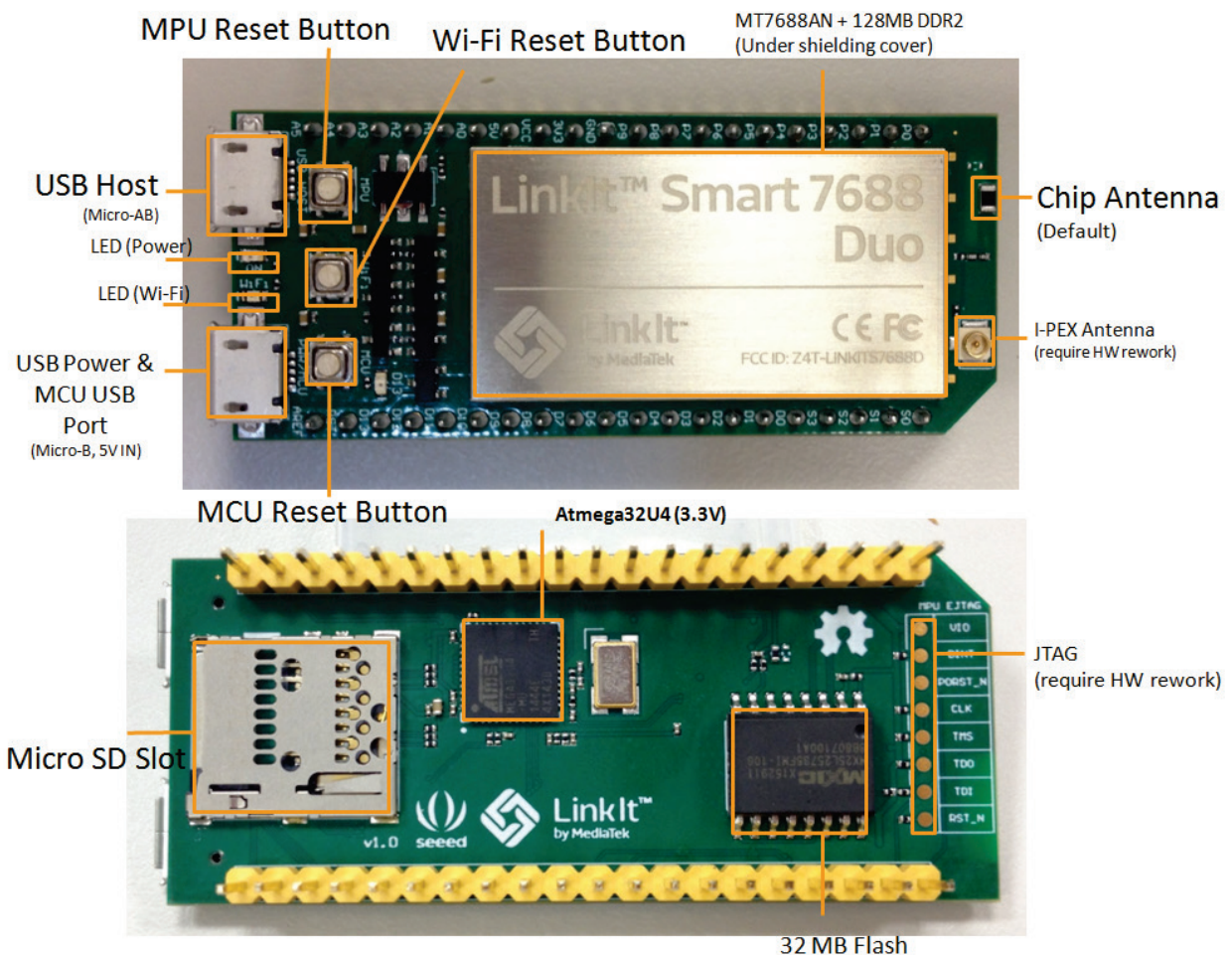

Figure 6 LinkIt Smart 7688 Duo development board (MPU + MCU)

1.4.2. Buttons

The buttons description on LinkIt Smart 7688 Duo and how to use them are described in Table 7.

Scenario	Button	Action
Resets the MPU	MPU Reset Button	One Press
Resets the MCU	MCU Reset Button	One Press
Enters MCU boot loader mode (Timeout after 8 seconds)	MCU Reset Button	Two Presses within 750 milliseconds
Resets Wi-Fi to AP mode	Wi-Fi Reset Button (After system is boot up)	Press for at least 5 seconds and release
Factory resets and enters AP mode WARNING: Restore to default setting and all user data will be removed from the device	Wi-Fi Reset Button (After system is boot up)	Press for at least 20 seconds and release
Upgrades firmware from a USB drive	Wi-Fi Reset Button (At power up)	Press for at least 5 seconds and release
Upgrades boot loader from a USB drive WARNING: Restore to default setting and all user data will be removed from the device	Wi-Fi Reset Button (At power up)	Press for at least 20 seconds and release

Table 6 LinkIt Smart 7688 Duo Development board buttons

1.4.3. LEDs

- Power

Power LED turns solid on in green color when power is supplied.

- Wi-Fi

Wi-Fi LED is in orange color and its blink pattern is described in Table 7 .

Mode	Status	LED blink pattern
AP Mode	With client device	3 blinks in 1 second and pause for 0.5 seconds (cycle repeats)
	Without client device	Off
Station Mode	Disconnected	Off
	Connecting	2 blinks in 1 second
	Data transmission	Blinking based on the transmitted data package

Table 7 Wi-Fi LED blink pattern in LinkIt Smart 7688 Duo

1.4.4. Antennas

LinkIt Smart 7688 Duo has the same antenna support as LinkIt Smart LinkIt Smart 7688. Please refer to 1.3.4“Antenna” for details.

1.4.5. USB Host

LinkIt Smart 7688 provides USB host capability which enables it to connect to different USB devices such as webcams, USB drives, keyboards, joysticks and more. The connector used is USB Micro-AB type.

1.4.6. USB Power

The USB cable provides 5V steady power source to LinkIt Smart 7688 Duo development boards. When you add peripheral devices such as SD card, USB drive or other USB devices to the development board, additional power may be consumed. Please use a proper USB cable to reduce power loss. If your peripheral device consumes power heavily, it's better to use an external power source for it.

The approximate power consumption of various devices connected to LinkIt Smart 7688 Duo is described in Table 8.

Scenario		Approximate Power Consumption
To establish Wi-Fi connection	Peak	596.4 mA
	Average	273.5 mA
Device boot up	Peak	672.6 mA
	Average	248.9 mA
Downloading file to a SD Card via Wi-Fi	Peak	605.4 mA
	Average	300.4 mA

Scenario		Approximate Power Consumption
Downloading a file to a USB Drive via Wi-Fi	Peak	616.6 mA
	Average	347.5 mA
Downloading a file to flash via Wi-Fi	Peak	578.5 mA
	Average	336.3 mA

Table 8 Peripherals Power Consumption

1.4.7. Accessories

LinkIt Smart 7688 Duo standard package comes with the development board only. The accessories are the same as LinkIt Smart 7688. Please refer to 1.3.7 "Accessories" for more information.

1.4.8. JTAG

You can use JTAG interface to debug MT7688AN. To access JTAG interface, you will need to unsolder resistor R95 and solder it to resistor R3 on the 7688 development board. After you've moved the resistor and reboot the device you'll activate JTAG function. The steps are:

- 1) Find a group of resistors on the bottom side of LinkIt Smart 7688 Duo (top-right view) as circled in Figure 7.

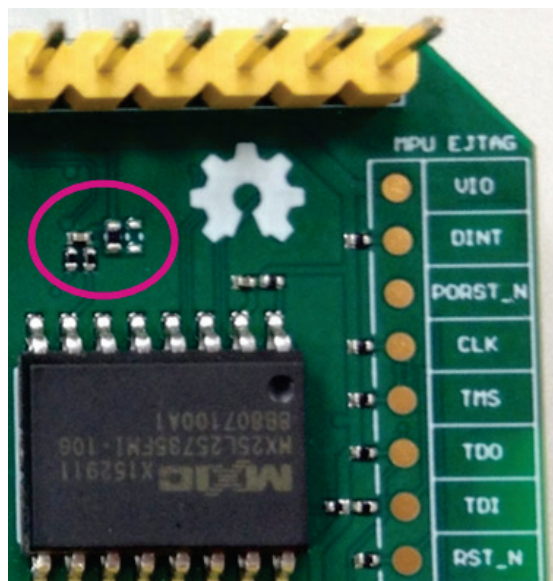

Figure 7 JTAG resistors on LinkIt Smart 7688 Duo bottom view

- 2) Next, you will move a resistor by unsoldering and soldering it to a lower position as shown in Figure 8, after you're finished moving the resistor, restart the device and you should be able to access JTAG mode.

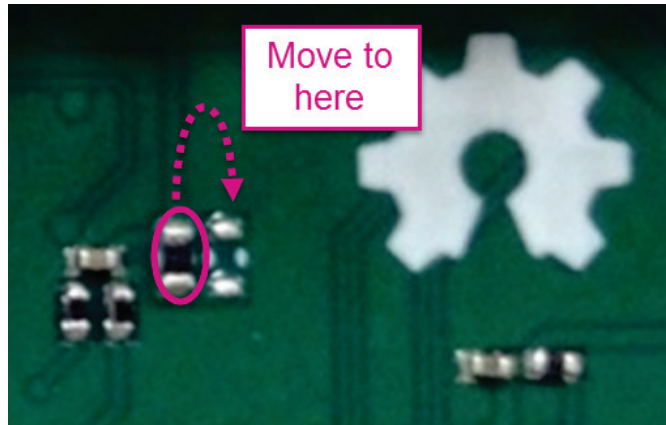

Figure 8 Moving a resistor to access JTAG mode

1.4.9. Specifications

The key specifications of LinkIt Smart 7688 Duo development board are shown in Table 9.

Category	Feature	LinkIt Smart 7688 Duo
MPU	Chipset	MT7688AN
	Core	MIPS24KEc
	Clock speed	580MHz
	Working voltage	3.3V
MCU	Chipset	ATmega32U4
	Core	Atmel AVR
	Clock speed	8MHz
	Working voltage	3.3V
PCB Size	Dimensions	60.8 x 26 mm
Memory	Flash	32MB
	RAM	128MB DDR2
Power Source	USB Power	5V (USB Micro-B)
	VCC	3.3V (Pin Breakout)
GPIO	Pin Count	3 (MT7688AN) 24 (ATmega32U4)
	Voltage	3.3v
PWM	Pin Count	8 (ATmega32U4)
	Voltage	3.3v
	Max. Resolution	16 bits (customizable)

Category	Feature	LinkIt Smart 7688 Duo
	Maximum Frequency@ Resolution	31.25kHz@8-bit Timer 0 (4 sets) 2MHz@2-bit 122Hz@16-bit Timer 1 & 3 (4 sets) 187.5kHz@8-bit 46.875kHz@10-bit Timer 4 (6 sets)
ADC	Pin Count	12 (ATmega32U4)
	Voltage	3.3v
External Interrupts	Pin Count	8 (ATmega32U4)
SPI/SPIS	Set count	1 (ATmega32U4)
	Pin numbers	S0, S1, S2, S3
	Max. Speed	4 MHz
I2C	Set Count	1
	Pin numbers	D2, D3
	Speed	400K
UART (Lite)	Set Count	1 (MT7688AN)
		1 (ATmega32U4)
	Pin numbers	P8, P9 (MT7688AN)
		D0, D1 (ATmega32U4)
Max. Speed	115,200 bps (MT7688AN)	
	0.5 Mbps (MT7688AN)	
USB Host	Set Count	1 (MT7688AN)
	Pin numbers	P6, P7
	Connector type	Micro-AB
Communication	Wi-Fi	802.11 b/g/n (2.4G)
	Ethernet	1-port 10/100 FE PHY
	Pin numbers	P2, P3, P4, P5
User Storage	SD Card	Micro SD SDXC

Table 9 LinkIt Smart 7688 Duo development board specifications

1.4.10. Pin-out Diagram

The LinkIt Smart 7688 Duo pin-out diagram is shown in the next page. You can also download LinkIt Smart 7688 Reference Design at MediaTek Labs website.

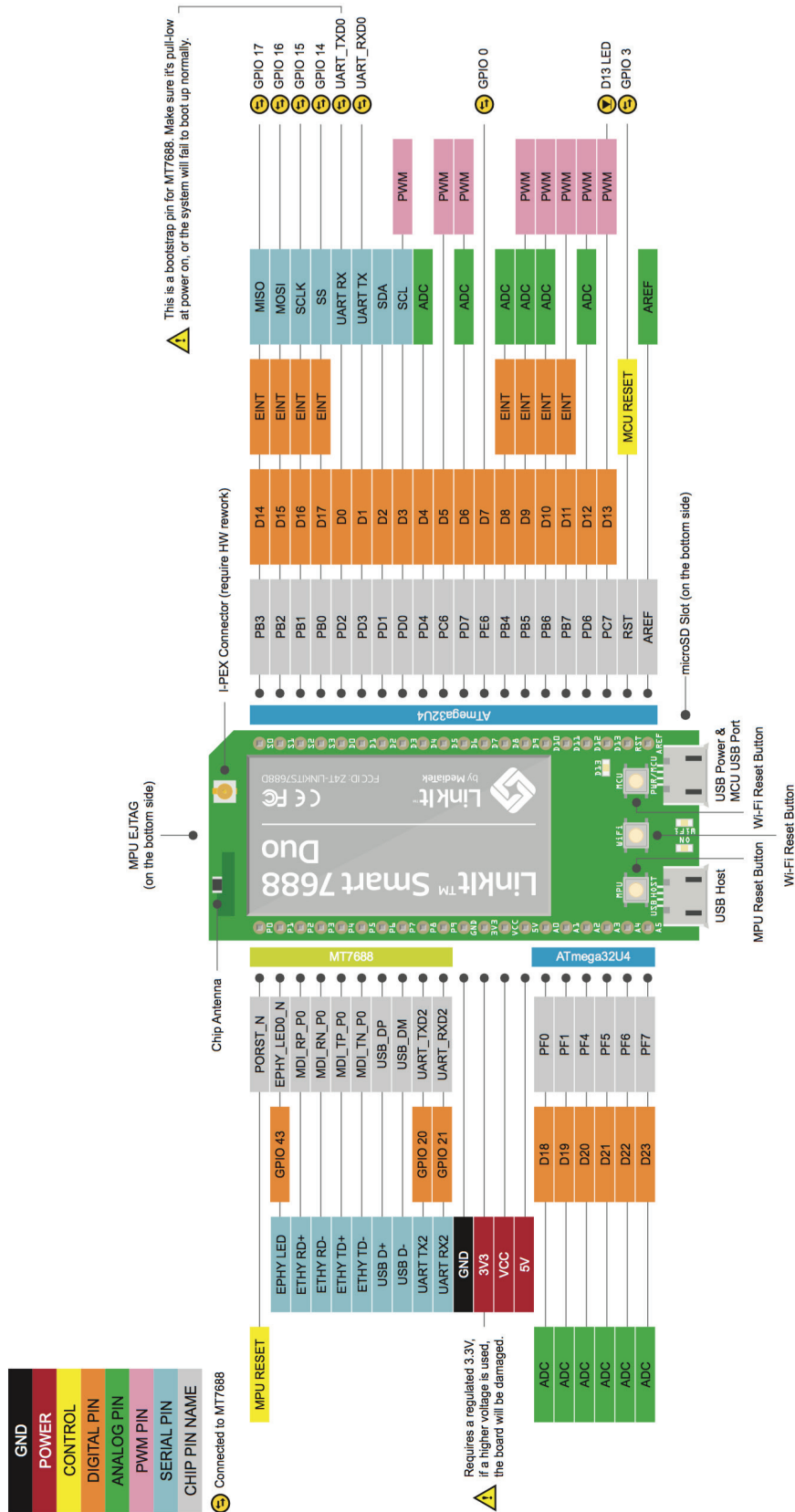

1.5. Joining the MediaTek Labs Ecosystem

Wearable and Internet of Things are the next wave in the consumer gadget revolution. MediaTek is a key player in this field, combining the best of two worlds –the existing MediaTek ecosystem of phone manufacturers, electronic device manufacturers, and telecom operators with the open, vibrant maker community world.

No matter whether you're a maker, device manufacturer, student, DIY hobbyist, or programmer, you can use this powerful yet simple platform to create something innovative. You can join the MediaTek LinkIt ecosystem by registering on labs.mediatek.com, we look forward to you joining our ecosystem and creating something great together.

2. Development Environment

2.1. Operating Systems

The following operating systems can be used to access LinkIt Smart 7688 development boards:

- Windows XP, 7, 8 and 10
- Mac OS X 10.9 and 10.10
- Linux Ubuntu 14.04 LTS

An overview of the OS capabilities is shown in Table 10:

OS	Windows	Ubuntu	Mac OS X
Arduino IDE (LinkIt Smart 7688 Duo only)	Yes	Yes	Yes
To build bootloader, firmware and C programs	No	Yes	Yes
Python, Node.js development	Yes	Yes	Yes

Table 10 OS Capabilities



If you are developing on a Windows computer you'll need to install a virtual machine with Linux development environment to build bootloader, firmware and programs in C.

2.2. OpenWrt Introduction

[OpenWrt](#) is an open-source embedded Linux operating system used mainly on embedded devices such as wireless routers. Key features of OpenWrt include the following:

- 1) Comprehensive network related functions
- 2) Provides a fully writable file system with package management
- 3) Rich and extendable feature set (over 3,400+ packages and growing)

2.3. Network Environment

Both LinkIt Smart 7688 development board can be configured in two modes: Access point or Station.

2.3.1. Access Point Mode

For local area network, LinkIt Smart 7688 acts as an AP. AP mode is used when you are configuring LinkIt Smart 7688. Figure 9 illustrates how LinkIt Smart 7688 works in a LAN environment.

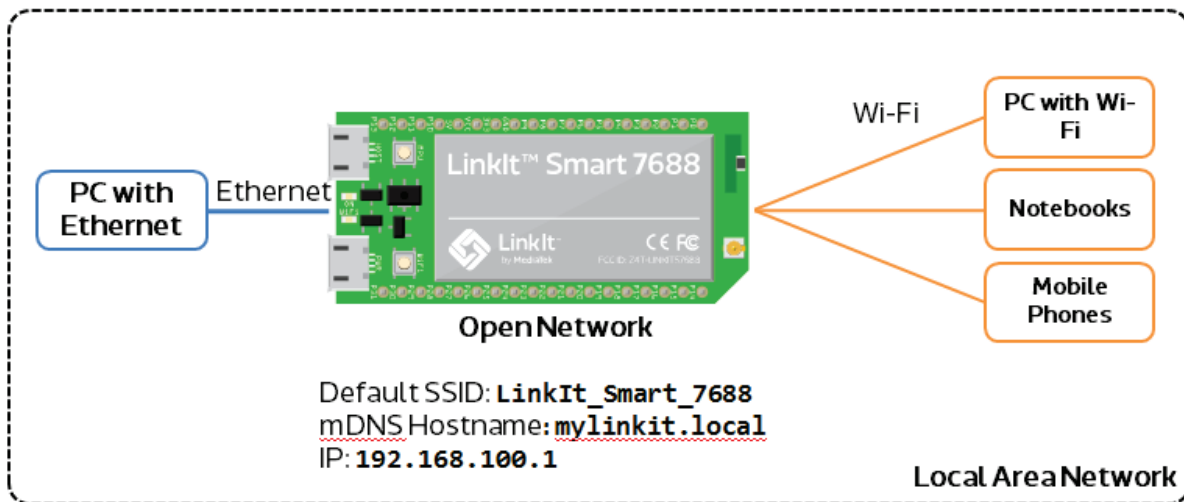

Figure 9 LinkIt Smart 7688 in AP Mode

2.3.2. Station Mode

For a network with Wi-Fi access point, LinkIt Smart 7688 acts as a station. Station mode is used when you want to install software from OpenWrt to LinkIt Smart LinkIt Smart 7688 HDK, for example. Figure 10 illustrates how LinkIt Smart 7688 works in a LAN with Wi-Fi AP.

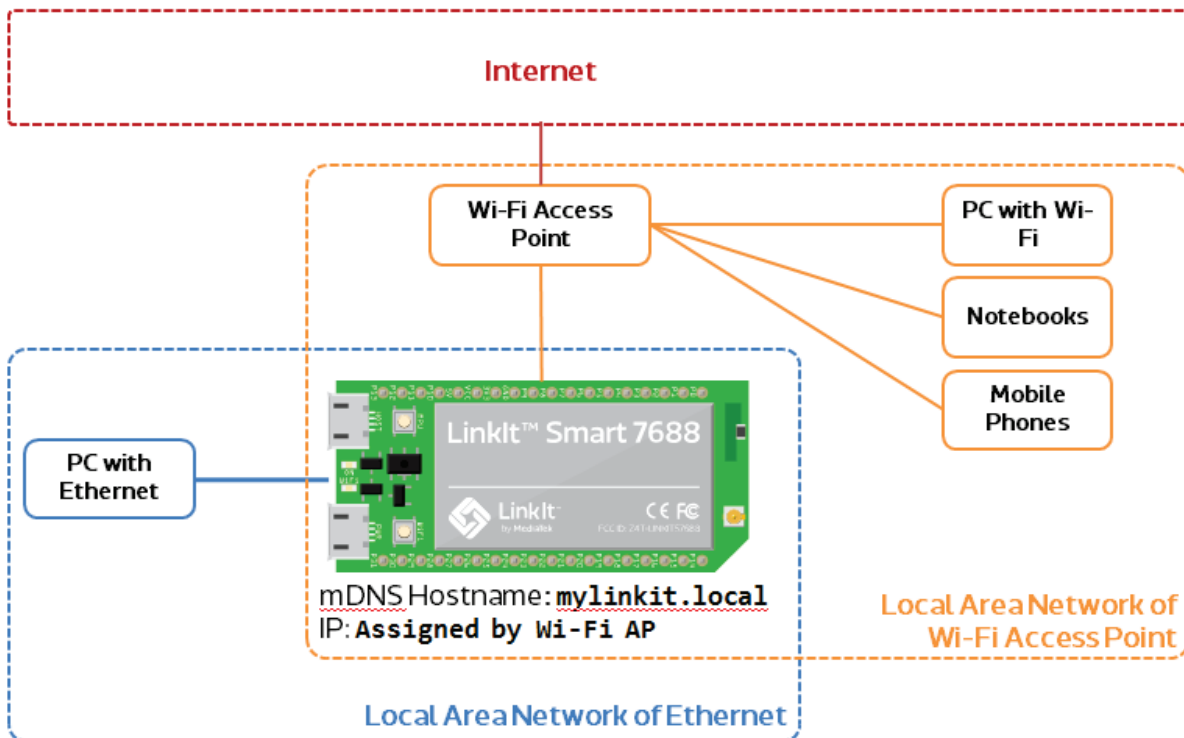

Figure 10 LinkIt Smart 7688 in Station Mode

2.4. System Configuration

This chapter describes the methods you can use to configure LinkIt Smart 7688 development board. The board uses a local domain called **myLinkIt.local** and your computer needs to support mDNS to use this local domain. For Windows 8 and later, Mac OS X and Linux, the mDNS is supported. However, if

you're using Windows 7, you'll need to install [Bonjour printing service](#) to help your computer discover LinkIt Smart 7688 (IP address) when in Station mode on a local area network with a Wi-Fi AP.

2.4.1. Accessing Web UI

LinkIt Smart 7688 Web UI allows you to configure system information, upgrade firmware, perform device reset and change between Wi-Fi AP and Client mode and more. The following steps apply to Windows, Mac OS X and Linux.

- 1) Power on LinkIt Smart 7688 by using any USB power source, for example your computer and a Micro USB cable as shown in Figure 11.

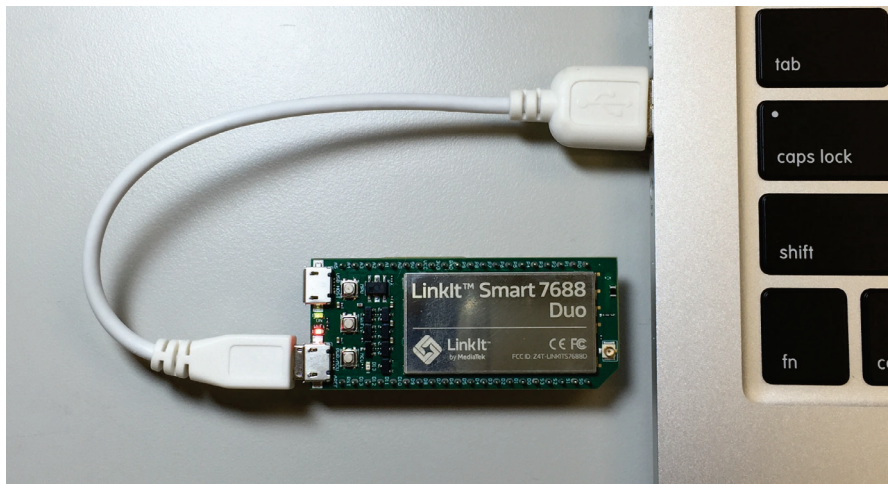

Figure 11 Connecting LinkIt Smart 7688 to a computer

- 2) Click the Wi-Fi icon  on your computer and connect to an access point named **LinkIt_Smart_7688**, as shown in Figure 12.



Figure 12 Connecting to LinkIt Smart 7688 AP

- 3) Open a web browser and type **http://myLinkIt.local** in the URL box. The Web UI page opens as shown in Figure 13.

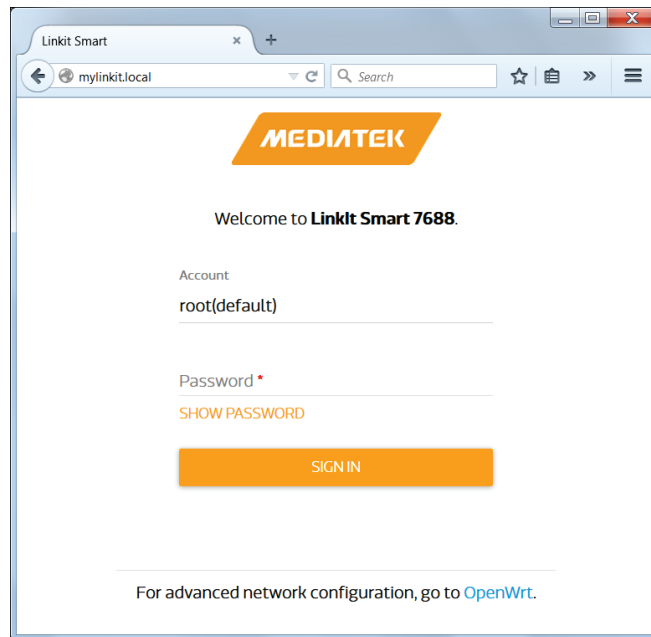

Figure 13 LinkIt Smart 7688 Web UI Sign In

- 4) Click on the Password field and set a password using at least 6 alphanumeric characters.



Note: You must set a password before using SSH to access system console.

2.4.2. Accessing System Console

There are two ways to access the system console on LinkIt Smart 7688 development board. They are described as follows:

2.4.3. Using SSH (Secure Socket Shell)

Before you start please make sure you've already set a password in the Web UI as described in 2.4.1 "Accessing Web UI" and the LinkIt Smart 7688 is in the same network as your computer.

For Mac and Linux, use the Terminal that's already installed in the computer.

- For Windows:

- 1) Install PuTTY from [here](#).
- 2) Open PuTTY and a Security Alert window will pop up, click **Yes**. Then, in the PuTTY Configuration window, type **myLinkIt.local** in the Host Name box, check the **SSH** radio button and click **Open** as shown in Figure 14.

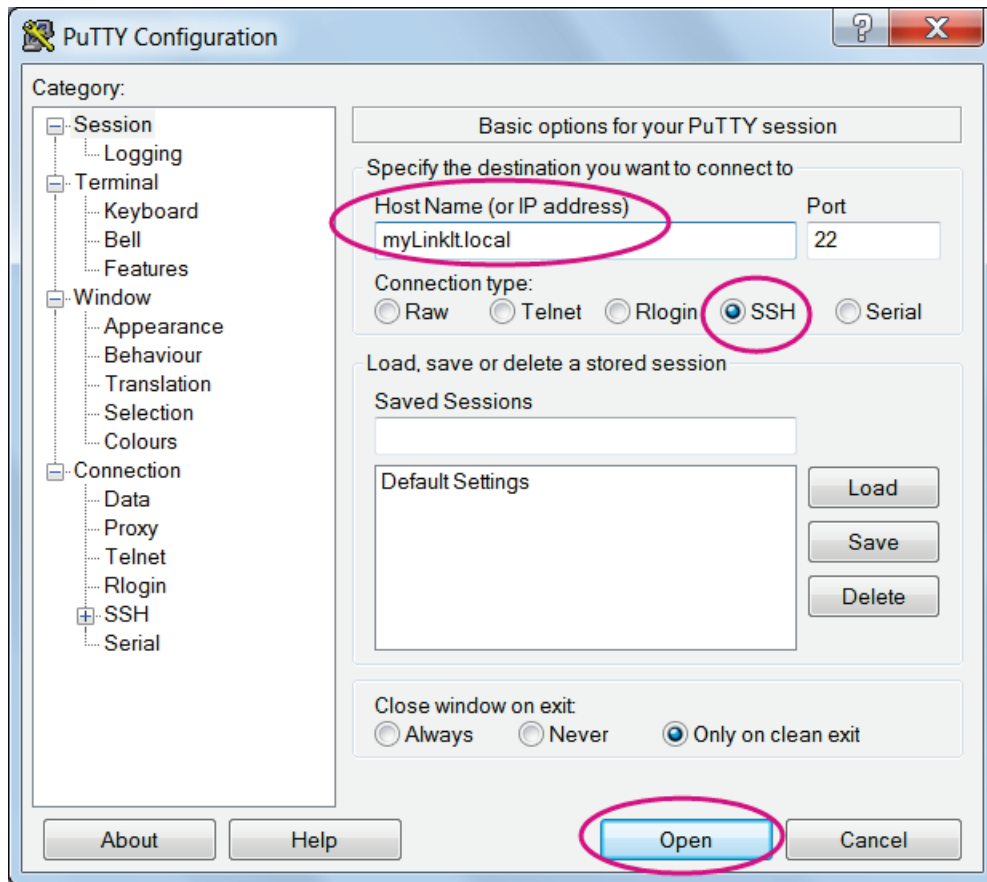
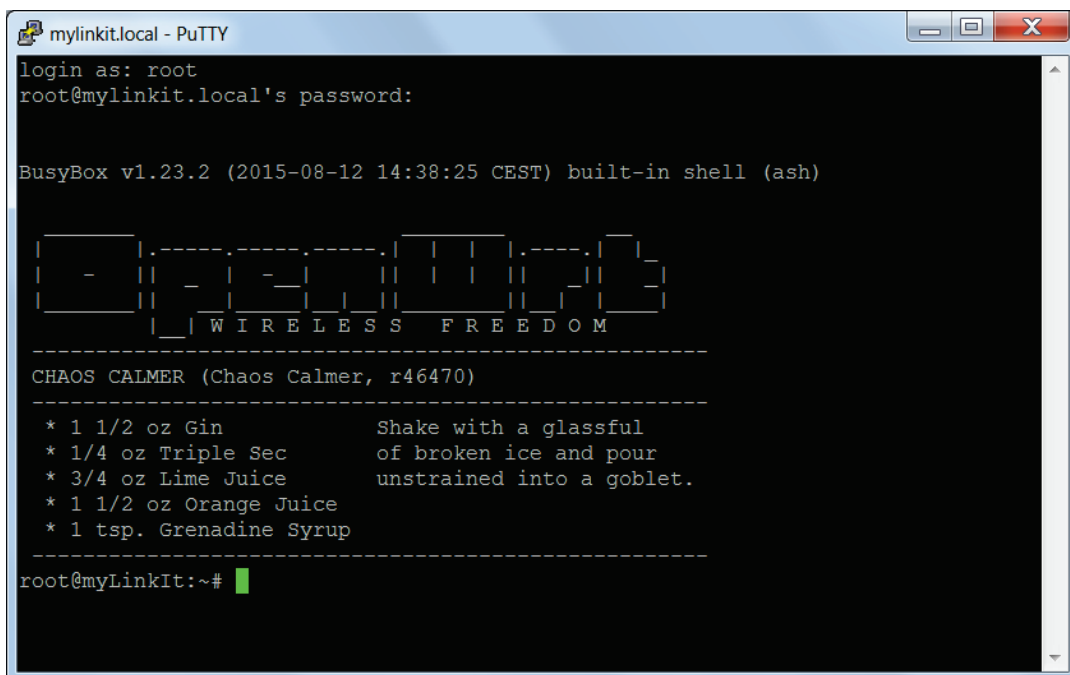

Figure 14 Using SSH in Windows PuTTY

- 3) In the PuTTY terminal window that opens, log in with username **root** and enter the password you set previously in the Web UI, after log in you should see a screen similar to below.



- For Mac:

Open Terminal. In the Terminal, type **ssh root@myLinkIt.local** at the command line, hit return and you'll be prompted to enter the root password. Enter the password you set previously in the Web UI.

- For Linux:

Open Terminal. In the Terminal, type **ssh root@myLinkIt.local** at the command line, hit return and log in using the password you set previously.

For more information on using SSH, please reference [here](#).

2.4.4. Using Serial to USB Cable

You can connect to the system console of LinkIt Smart 7688 by using a Serial (or UART) to USB cable. First, you need to check if your cable requires driver installation; it may or may not be needed. Please check the following sections per your OS.



Note: Download the executable version corresponding to your OS from the **Currently Supported VCP Drivers** list. After installation, the COM port will be successfully identified.

- For Windows:

- 1) Install driver. If you're using a USB cable based on FTDI chip please download and install its driver from [here](#). If you're having problems with the latest driver, try installing an [older version](#).
- 2) Next, you'll need to connect the Serial to USB cable to LinkIt Smart 7688's UART pins in the following table as shown in below:

UART to USB Cable	LinkIt Smart 7688 UART pins
RX	P8
TX	P9
GND	GND

Table 11 USB and LinkIt Smart 7688 UART Pin Mapping

- 3) Open the PuTTY terminal and enter the **COM port** number of the USB device found in the device manager, this number may be different on your computer. Click on the **Serial** radio button, type **57600** in Speed box and click **Open**, as shown in below.

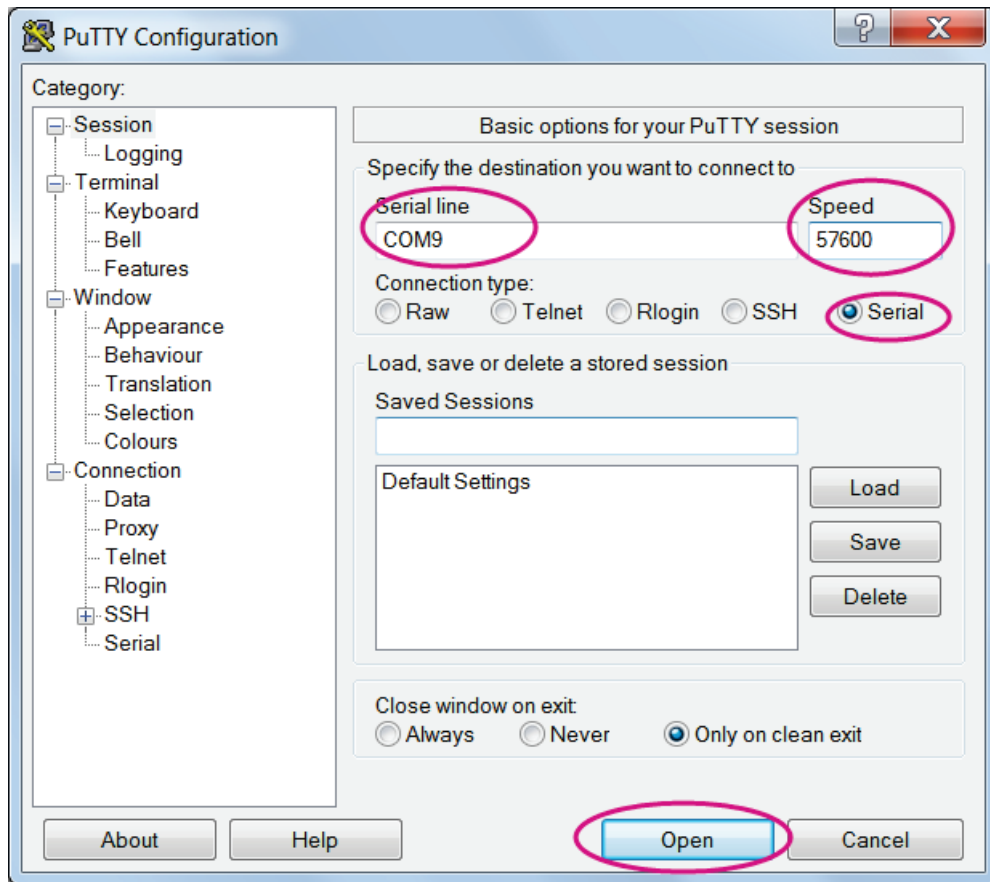

Figure 15 Using UART to USB cable to access system console in Windows terminal

- 4) To exit the system console, click the **X** on top right of the PuTTY windows.

● For Mac:

- 1) Install the driver if needed. Check the cable manufacturer’s website for driver requirements on Mac and installation instructions.
- 2) Plug-in the cable and connect the cable to LinkIt Smart LinkIt Smart 7688.
- 3) Open a Terminal session. You can open it at Applications/Utilities/Terminal.
- 4) Type **ls /dev/cu*** in the Terminal. You should see a list of devices. Look for something like **cu.usbserial-XXXXXXXX** where **XXXXXXXX** is usually a random identifier. This is the serial device used to access the system console. For example:

```
$ls /dev/cu*
/dev/cu.Bluetooth-Incoming-Port
/dev/cu.Bluetooth-Modem
/dev/cu.pablop-WirelessiAP
/dev/cu.usbserial-A6YMCQBR
```

- 5) Use the **screen** utility to connect to the serial port and set the baudrate to **57600**. This is because the baudrate of the system console is **57600** by default. For example:

```
$screen /dev/cu.usbserial-XXXXXXXX 57600
```

- 6) Now you should be connected to the system console. Press **ENTER** in the Terminal to bring up the prompt. You'll notice that the prompt has become different from your OS X Terminal application, it is the LinkIt Smart 7688 prompt and it looks like the following:

```
root@myLinkIt:/#
```

- 7) You're ready to make changes to the LinkIt Smart 7688 system through this console.
- 8) To exit the system console, type **<CTRL>a + k**, and **y**.

- For Linux:

- 1) Install the driver if needed. Check the cable manufacturer's website for driver requirements on Ubuntu and installation instructions.
- 2) Plug-in the cable and connect the cable to LinkIt Smart LinkIt Smart 7688.
- 3) Open a Terminal application.
- 4) Type **ls /dev/ttyUSB*** in the Terminal. You should see a list of devices. Look for something like **ttyUSB0** where **0** is usually a random identifier. This is the serial device used to access the system console. For example:

```
$ls /dev/ttyUSB*
/dev/ttyUSB0
```

- 5) Use the **screen** utility to connect to the serial port and set the baudrate to **57600**. This is because the baudrate of the system console is **57600** by default. One thing to keep in mind is that in Ubuntu, the serial devices require **dialout** group permission. Use **sudo** to elevate the permission, for example:

```
$sudo screen /dev/ttyUSB0 57600
```

- 6) Now you should be connected to the system console. Press **ENTER** in the Terminal to bring up the prompt. You'll notice that the prompt has become different from your Linux Terminal application, it is the LinkIt Smart 7688 prompt and it looks like the following:

```
root@myLinkIt:/#
```

- 7) You're ready to make changes to the LinkIt Smart 7688 system through this console.
- 8) To exit the system console, type **<CTRL>a + k**, and **y**.

2.4.5. Upgrading Firmware

This section describes how to upgrade the firmware on both LinkIt Smart 7688 development boards (same firmware). You can choose from one of the following two ways to upgrade firmware:

- Using Web UI:

- 1) Sign in the LinkIt Smart 7688 Web UI. Please see 2.4.1 "Accessing Web UI" if you haven't signed in before.
- 2) After you've signed in, click on the Upgrade firmware button as shown in Figure 16.

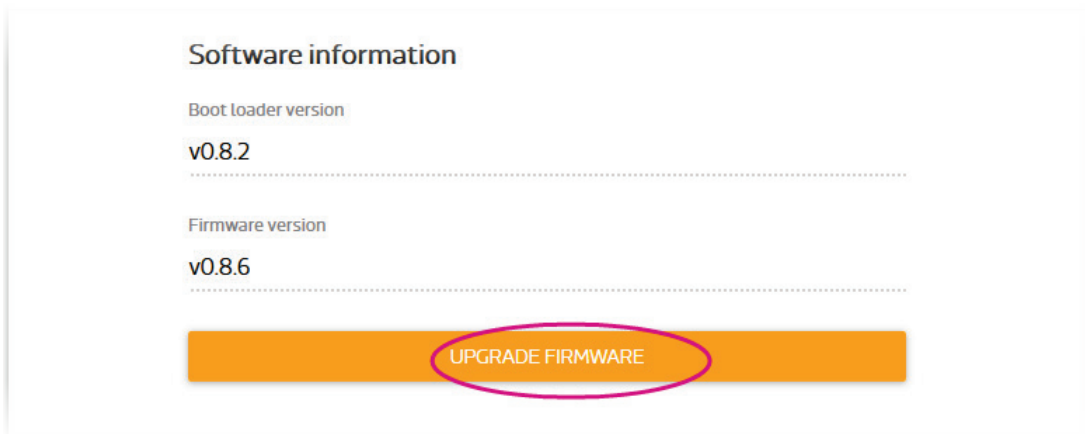

Figure 16 Firmware upgrade button

- 3) Click under **Upgrade firmware file** and choose the **lks7688.img** file. Click **Upgrade & Restart** button as shown in Figure 17.

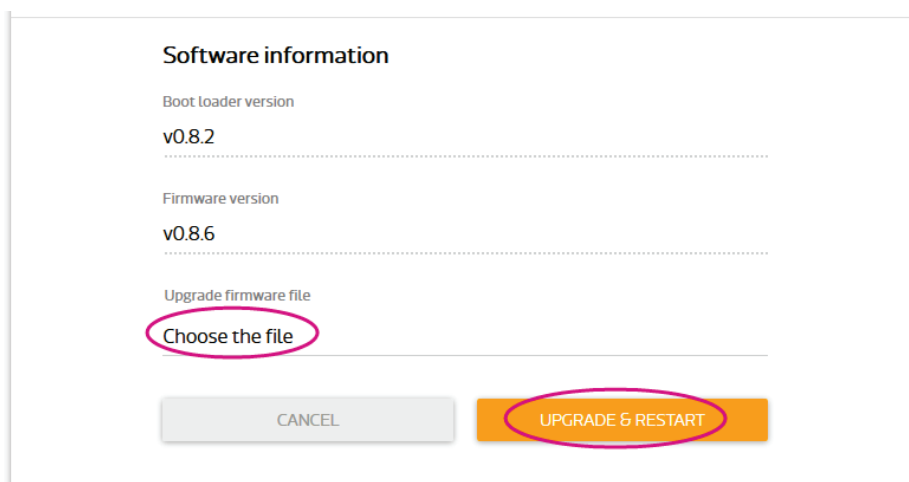

Figure 17 Selecting firmware file

The firmware will upload to LinkIt Smart 7688 and the reboot will start. This process takes about 3 minutes. When you see three short blinks on the LinkIt Smart 7688, it indicates the firmware has been upgraded.



Note: Performing firmware upgrade will remove all user data from the development board.

- Using USB drive :

- 1) Save the firmware file (**lks7688.img**) in the root directory of a USB drive. You can download the latest firmware from MediaTek Labs website.
- 2) Plug the USB drive to LinkIt Smart 7688.
- 3) Press the Wi-Fi and MPU (Reset) button at the same time, then release the MPU Reset button only but hold the Wi-Fi button for at least 5 seconds (Wi-Fi LED will turn off) and release. **Warning:** Do not press the Wi-Fi button for longer than 20s or it will enter boot loader mode.
- 4) LinkIt Smart 7688 will start to read the firmware image (Wi-Fi LED blinks fast) and perform the firmware upgrade process (Wi-Fi LED blinks slowly). It takes about 3 minutes to finish the firmware upgrade process.

2.4.6. Upgrading bootloader



Warning: Do not disconnect the power source or unplug the USB drive during bootloader upgrading process, or else the data in flash will be damaged and you will not be able to boot up again.

This section describes how to upgrade the bootloader.

Please follow these steps:

- 1) Save the bootloader file (**lks7688.ldr**) in the root directory of a USB drive and name it **lks7688.ldr** you can download the latest bootloader from MediaTek Labs website.
- 2) Plug the USB drive to LinkIt Smart LinkIt Smart 7688 HDK.
- 3) Press the Wi-Fi and MPU (Reset) button at the same time, then release the MPU Reset button only but hold the Wi-Fi button for at least 20 seconds (after 20s Wi-Fi LED will turn on)and release.
- 4) LinkIt Smart 7688 development board will start to read the bootloader (Wi-Fi LED blinks fast) and perform the bootloader upgrade process (Wi-Fi LED blinks slowly). It takes 2 seconds to finish the bootloader upgrade process.

2.4.7. Wi-Fi Reset

Press the Wi-Fi Reset button for at least 5 seconds and release. The device will go into AP mode.

2.4.8. Factory Reset

This section describes how to do factory reset on LinkIt Smart 7688 development board. Factory reset will erase all user data from the board, so proceed with caution. Choose from one of the following two ways to perform factory reset.

- Using Web UI

- 1) Sign in the Web UI 2.4.1 "Accessing Web UI" and click the Reset button under Factory Reset, as shown in Figure 18.

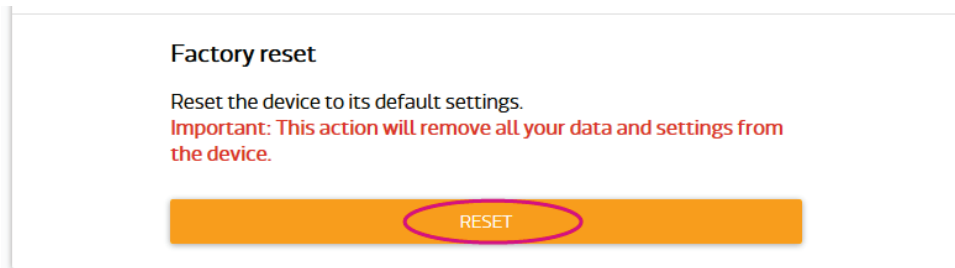

Figure 18 Factory Reset using LinkIt Smart 7688 Web UI

- Using the Wi-Fi Reset button

After LinkIt Smart 7688 is boot up (power LED solid on, Wi-Fi LED), press the **Wi-Fi Reset button** for at least 20 seconds and release. Please see Figure 1 for Wi-Fi Reset button locations. LinkIt Smart 7688 development board will reboot to default settings and all user data will be eliminated from the board, so proceed with caution.

2.4.9. Connecting LinkIt Smart 7688 To a network with Wi-Fi Access Point

This section describes the two ways LinkIt Smart 7688 development board connects to a network that is not in the same network as the computer it's connected to. To connect to an access point, LinkIt Smart 7688 needs to be in Station mode.

- Using OpenWrt's UCI ([Unified Configuration Interface](#))

2.4.10. Open a system console and enter the following commands to change LinkIt Smart 7688 to station mode (For more information on system console, please see 2.4.1 "Accessing Web UI

LinkIt Smart 7688 Web UI allows you to configure system information, upgrade firmware, perform device reset and change between Wi-Fi AP and Client mode and more. The following steps apply to Windows, Mac OS X and Linux.

- 2) Power on LinkIt Smart 7688 by using any USB power source, for example your computer and a Micro USB cable as shown in Figure 11.

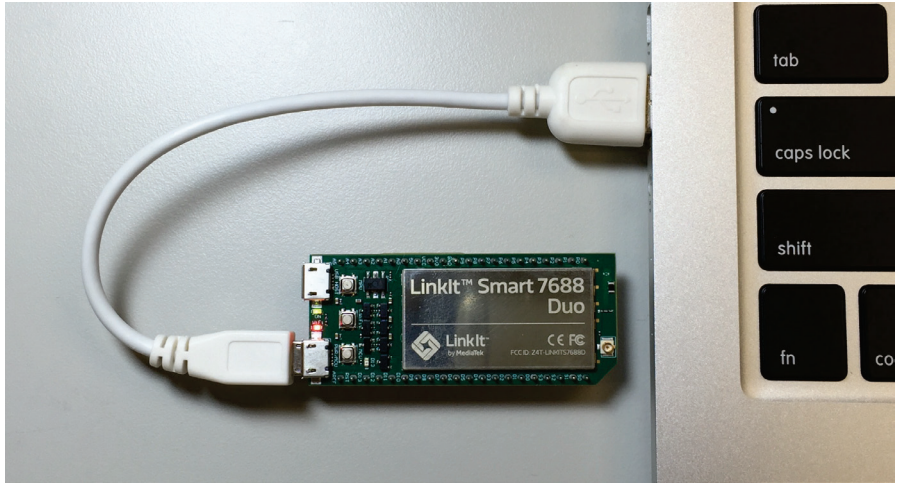

Figure 11 Connecting LinkIt Smart 7688 to a computer

- 3) Click the Wi-Fi icon  on your computer and connect to an access point named **LinkIt_Smart_7688**, as shown in Figure 12.



Figure 12 Connecting to LinkIt Smart 7688 AP

- 4) Open a web browser and type **http://myLinkIt.local** in the URL box. The Web UI page opens as shown in Figure 13.

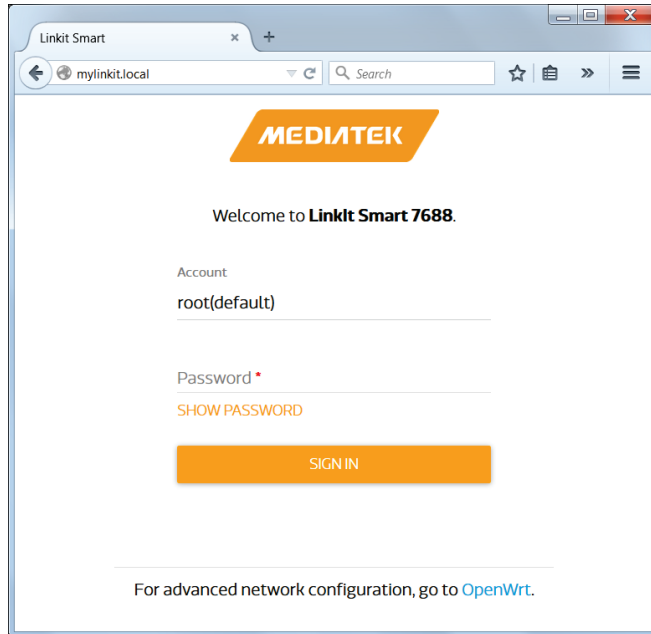

Figure 13 LinkIt Smart 7688 Web UI Sign In

- 5) Click on the Password field and set a password using at least 6 alphanumeric characters.



Note: You must set a password before using SSH to access system console.

- 1) Accessing System Console"):

In this example, the following AP is used:

- AP SSID: **MyAP**
- Encryption type: **PSK2**
- Password: **12345678**

```
# uci set wireless.sta.ssid=MyAP
# uci set wireless.sta.encryption=psk2
# uci set wireless.sta.key=12345678
# uci set wireless.sta.disabled=0
# uci commit
# wifi down
# wifi up
```

- 2) Now check if you've established network connection by typing the following command in the terminal window:

```
# ping www.mediatek.com
```

If you see a screen similar to Figure 19, congratulations, you've connected to the Wi-Fi network's AP.

```

root@myLinkIt:/# ping www.mediatek.com
PING www.mediatek.com (175.98.146.37): 56 data bytes
64 bytes from 175.98.146.37: seq=0 ttl=245 time=39.076 ms
64 bytes from 175.98.146.37: seq=1 ttl=245 time=38.717 ms
64 bytes from 175.98.146.37: seq=2 ttl=245 time=39.250 ms
64 bytes from 175.98.146.37: seq=3 ttl=245 time=118.304 ms
64 bytes from 175.98.146.37: seq=4 ttl=245 time=118.949 ms
    
```

Figure 19 LinkIt Smart 7688 in Station mode connected to a Wi-Fi AP

● Using Web UI

Open a browser and type in **myLinkIt.local**. Please see 2.4.1“Accessing Web UI” if you’ve not signed in before.

- 1) Click Network button on upper right as shown in Figure 20

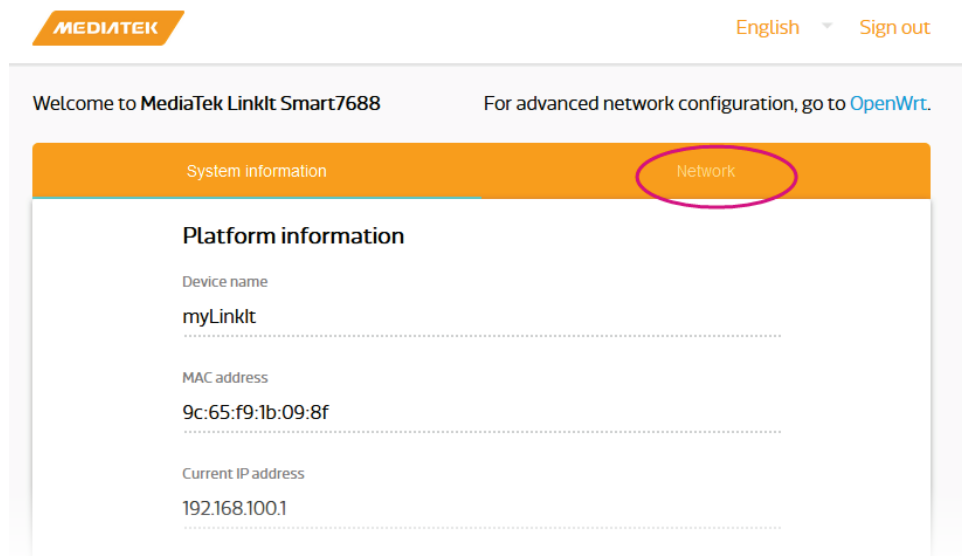

Figure 20 Change networking setting in Web UI

- 2) Select the **station mode** and click the **Refresh** button or **downward arrow** on the right to find the AP to connect to. After you’ve selected the AP, enter password if required. Click **Configure & Restart** button to finish as shown in Figure 21.

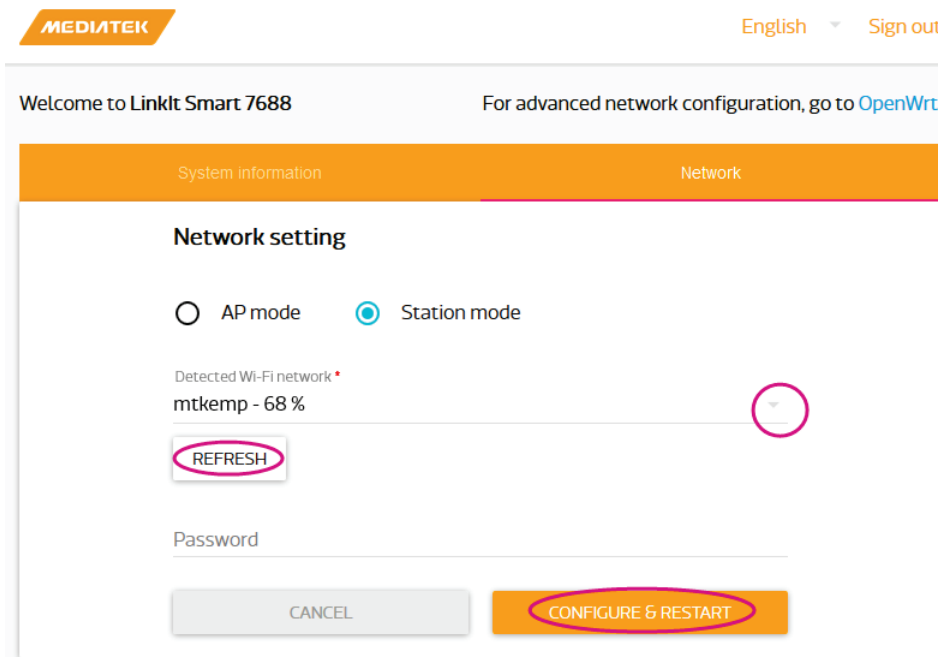

Figure 21 Changing to Station mode in Web UI

- 3) A message window will pop up letting you know the device is connecting to the AP you've selected.
- 4) Notice the Wi-Fi LED, it should blink once a second, this indicates LinkIt Smart 7688 is in Station mode.
- 5) To change LinkIt Smart 7688 back to AP mode, press the Wi-Fi Reset button for at least 5 seconds and release. When you see three short blinks on Wi-Fi LED, it is in AP mode.

2.4.11. Viewing System Information from the Web UI

You can view LinkIt Smart 7688's system information from any browser. After you've connected the LinkIt Smart 7688 to a network, open a browser and type **http://myLinkIt.local** in the URL box and sign in 2.4.1 "Accessing Web UI". Click the **Configure** button under System information and the following information will display, as shown in Figure 22:

- Device name
- MAC address
- Current IP address
- Account/Password
- Bootloader/Firmware version

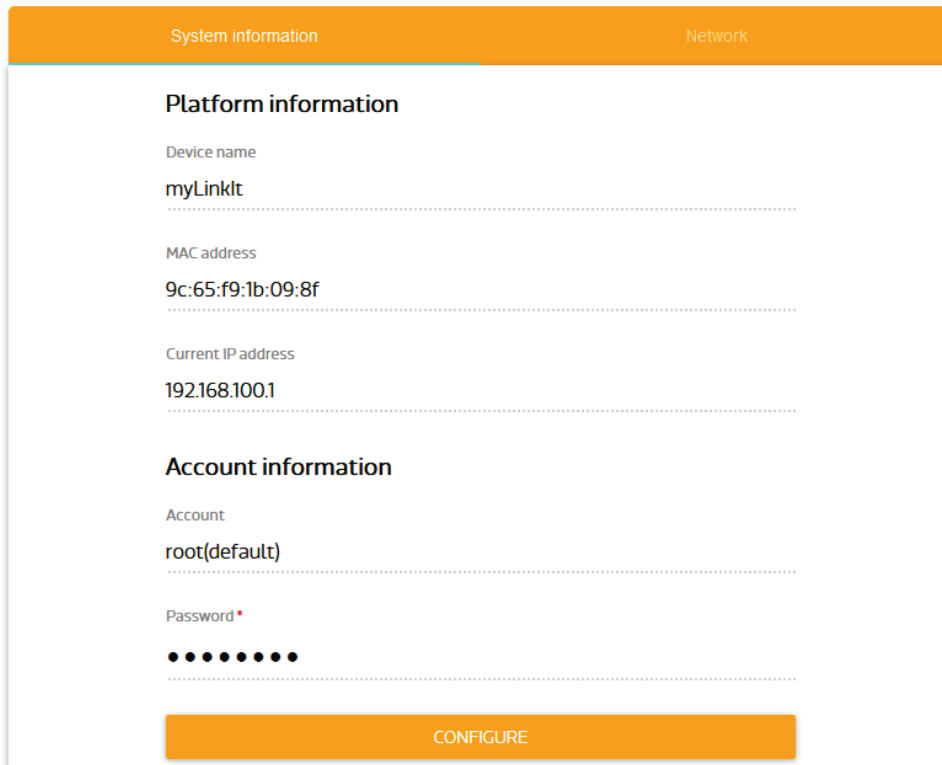

Figure 22 System Information in LinkIt Smart 7688 Web UI

2.5. Accessing the USB drive and the SD card

When a USB drive or SD card is inserted into LinkIt Smart 7688, they can be accessed under **/Media/SD*** or **/Media/USB*** (The device name displayed varies depending on the number of drives you use and the number of partitions available on the USB drive or SD card).

You can use the following commands to check the contents of the USB drive and SD card:

- In this example, a USB drive named **USB-A1** is used:

```
> ls /Media/USB-A1
```

- In this example, a SD card named **SD-P1** is used:

```
> ls /Media/SD-P1
```

Federal Communication Commission Interference Statement

This device complies with Part 15 of the FCC Rules. Operation is subject to the following two conditions: (1) This device may not cause harmful interference, and (2) this device must accept any interference received, including interference that may cause undesired operation.

This equipment has been tested and found to comply with the limits for a Class B digital device, pursuant to Part 15 of the FCC Rules. These limits are designed to provide reasonable protection against harmful interference in a residential installation. This equipment generates, uses and can radiate radio frequency energy and, if not installed and used in accordance with the instructions, may cause harmful interference to radio communications. However, there is no guarantee that interference will not occur in a particular installation. If this equipment does cause harmful interference to radio or television reception, which can be determined by turning the equipment off and on, the user is encouraged to try to correct the interference by one of the following measures:

- Reorient or relocate the receiving antenna.
- Increase the separation between the equipment and receiver.
- Connect the equipment into an outlet on a circuit different from that to which the receiver is connected.
- Consult the dealer or an experienced radio/TV technician for help.

FCC Caution:

- Any changes or modifications not expressly approved by the party responsible for compliance could void the user's authority to operate this equipment.
- This transmitter must not be co-located or operating in conjunction with any other antenna or transmitter.

Radiation Exposure Statement:

This equipment complies with FCC radiation exposure limits set forth for an uncontrolled environment. This equipment should be installed and operated with minimum distance 20cm between the radiator & your body.

This device is intended only for OEM integrators under the following conditions:

- 1) The antenna must be installed such that 20 cm is maintained between the antenna and users, and the maximum antenna gain allowed for use with this device is -3 dBi.
- 2) The transmitter module may not be co-located with any other transmitter or antenna.

As long as 2 conditions above are met, further transmitter test will not be required. However, the OEM integrator is still responsible for testing their end-product for any additional compliance requirements required with this module installed

IMPORTANT NOTE: In the event that these conditions can not be met (for example certain laptop configurations or co-location with another transmitter), then the FCC authorization is no longer considered valid and

the FCC ID can not be used on the final product. In these circumstances, the OEM integrator will be responsible for re-evaluating the end product (including the transmitter) and obtaining a separate FCC authorization.

End Product Labeling

This transmitter module is authorized only for use in device where the antenna may be installed such that 20 cm may be maintained between the antenna and users. The final end product must be labeled in a visible area with the following: "**Contains FCC ID: Z4T-LINKITS7688**". The grantee's FCC ID can be used only when all FCC compliance requirements are met.

Manual Information To the End User

The OEM integrator has to be aware not to provide information to the end user regarding how to install or remove this RF module in the user's manual of the end product which integrates this module. The end user manual shall include all required regulatory information/warning as show in this manual.