

FN-8110M Manual (OEM INTEGRATOR MANUAL)

FN-8110M MINI wireless modular

Product features:

USB bus interface

Meet IEEE 802.11 b/g/n/standard

Supports WEP/WPA/WPA2 data encryption

Product description:

Meet IEEE 802.11 n, IEEE 802.11 g, IEEE 802.11 b standard

USB interface

With two working mode: centralized control type (Infrastructure) and to the equation (Ad-Hoc)

Support 64/128/152-bit WEP data encryption

Support the WPA/WPA-PSK, WPA2 / WPA2-PSK advanced encryption and authentication mechanism of safety

Support wireless Roaming technology, ensure efficient wireless connection

The transmission distance, indoor farthest 20 meters; Outdoor as far as 50 meters (environmental factors on the distance has influence)

Support Windows 2000/XP/Vista/WIN 7/WIN CE/LINUX/MAC OS Android Operating system

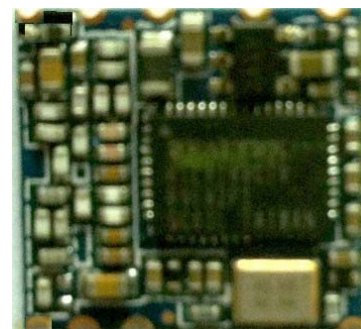

The detailed specification:

Model	FN-8110M
Agreement	IEEE 802.11n、 IEEE 802.11g、 IEEE 802.11b、 CSMA/CA with ACK
Bus type	USB 2.0&1.1
Frequency range	2.4~2.4835GHz
Working channel	1-14
Modulation mode	802.11 g/n: OFDM
	802.11b: CCK(11, 5.5Mbps), QPSK(2Mbps), BPSK(1Mbps)
Transmission rate	802.11b: 11,5.5,2,1 Mbps
	802.11g: 54,48,36,24,18,12,9,6 Mbps
	802011n: up to 150Mbps
Rx sensitivity	130M : -65dBm@10% PER; 108M: -65dBm@10% PER; 54M: -65dBm@10% PER; 11M: -87dBm@8% PER; 6M: -90dBm@10% PER; 1M: -90dBm@8% PER
Transmission distance	Indoor farthest 20 meters, outdoor farthest 50 m (for environment and different)
RF power	16dBm (maximum)
Antenna gain	1dBi PCB antenna ,have reserved the outer antenna interface
Technology	DSSS (Direct sequence exhibition frequency)
Working voltage	3.3V, 5V Can choose

LED instructions	Can increase
Envelop dimensions	22* 13.5*2mm
Use of the environment	Working temperature: -20°C-45°C
	Storage temperature: -40°C-70°C
	Work humidity: 10%-90%RH
	Storage humidity: 5%-90%RH
Support operating system	Windows 2000/XP/Vista/WIN 7/WIN CE/LINUX/MAC OS
Chip solutions	realtek RTL8188CTV

Typical application.

The wireless Internet access, MID, network cameras, STB GPS, hard disk player, PSP, need to implement wireless networking equipment

Pin definition:

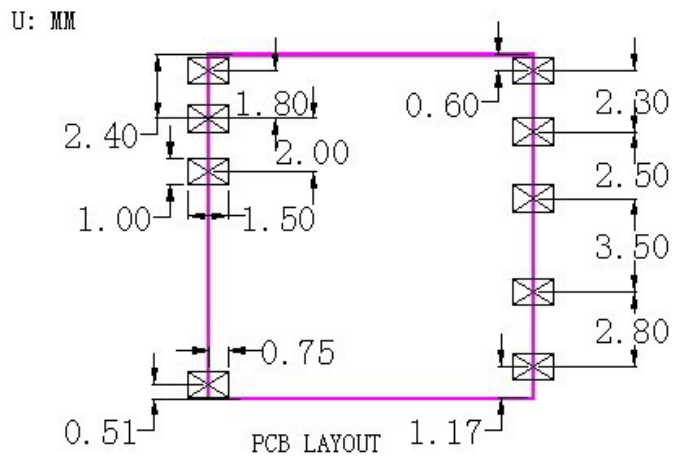
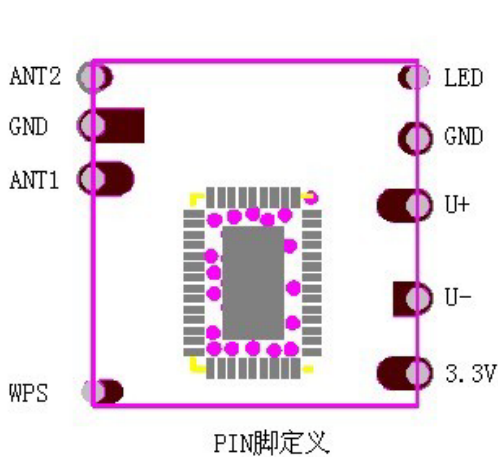

参考连线

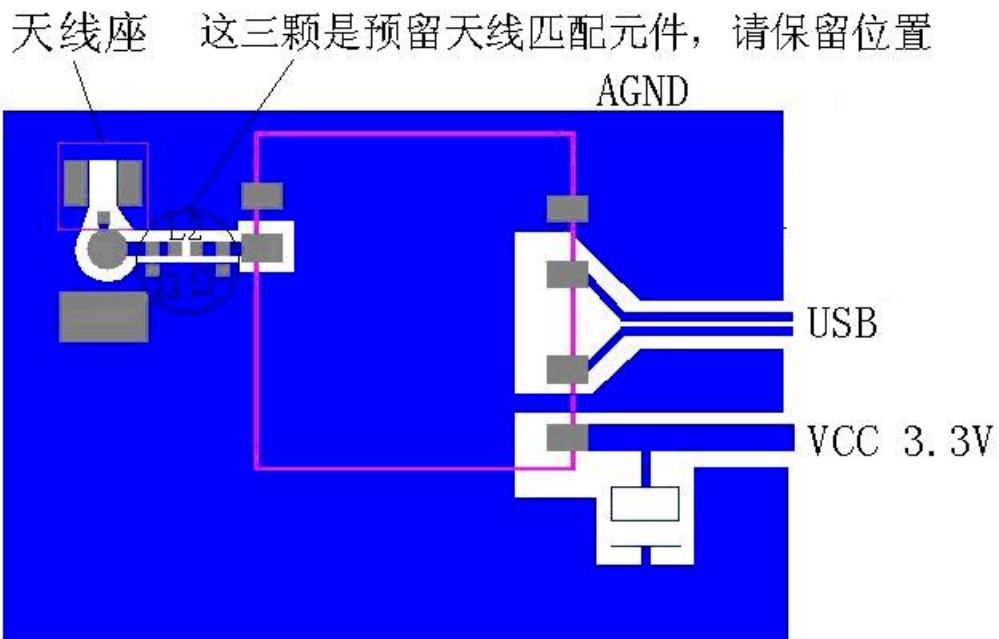

备注：RF输出走线尽量最短，保持50欧姆阻抗。

PCBA For single SMT placement process

- VCC : The power supply 3.3 V
- U- : USB data Pin
- U+ : USB data Pin
- GND : grounding
- LED : External work instructions LED
- WPS : External WPS confidential switch, high potential effective

Model application that:

Model	Characteristics	25°C Test environment	Application
FN-8110M-A	3.3V power supply MINI Low temperature version	Chip temperature 50-55°C	External antenna
FN-8110M-B-CTV	3.3V power supply normal temperature	Chip temperature 65-72°C	External antenna
FN-8110M-B-CUS	3.3V power supply MINI CUS	Chip temperature 50-55°C	External antenna

Test report

Frequency corresponding

Channel	1	2	3	4	5	6	7	8	9	10	11	12	13	14
Mhz	2412	2417	2422	2427	2432	2437	2442	2447	2452	2457	2462	2467	2472	2484

Transmitter Power (Unit in dBm) (Typical 1,6,13 Channel)

11b mode

mode	Rate	Channel 1	Channel 6	Channel 13
11b CCK	1Mbps	17.5	17.4	17.4
	2Mbps	17.4	17.4	17.2
	5.5Mbps	17.5	17.5	17.4
	11Mbps	17.0	17.1	17.3

11g mode

mode	Rate	Channel 1	Channel 6	Channel 13
11g OFDM	6Mbps	17.3	17.4	17.3
	18Mbps	17.5	17.3	17.2
	36Mbps	15.4	15.4	15.3
	54Mbps	14.2	14.3	14.5

11n 20MHz mode

mode	Rate	Channel 1	Channel 6	Channel 13
11n 20MHz	MCS0	15.5	15.3	15.4
	MCS3	15.3	15.4	15.3
	MCS5	15.5	15.2	15.5
	MCS7	14.3	14.5	14.4

11n 40MHz mode

mode	Rate	Channel 1	Channel 6	Channel 13
11n 40MHz	MCS0	15.6	15.4	15.3
	MCS3	15.5	15.2	15.4
	MCS5	15.3	15.5	15.6
	MCS7	14.5	14.2	14.3

EVM
11b mode: unit in %

mode	Rate	Channel 1	Channel 6	Channel 13
11b CCK	1Mbps	5.2	5.3	5.5
	2Mbps	5.4	5.3	5.5
	5.5Mbps	5.6	5.3	5.5
	11Mbps	5.9	5.6	5.9

11g mode: unit in dB

mode	Rate	Channel 1	Channel 6	Channel 13
11g OFDM	6Mbps	-29.3	-29.5	-29.1
	18Mbps	-29.2	-28.5	-29.3
	36Mbps	-28.5	-28.9	-28.1
	54Mbps	-29.8	-29.1	-29.0

11n 20MHz mode: unit in dB

mode	Rate	Channel 1	Channel 6	Channel 13
11n 20MHz	MCS0	-28.3	-28.5	-28.5
	MCS3	-28.2	-29.5	-28.4
	MCS5	-28.3	-28.5	-28.1
	MCS7	-28.1	-28.4	-28.0

11n 40MHz mode: unit in dB

mode	Rate	Channel 1	Channel 6	Channel 13
11n 40MHz	MCS0	-27.3	-27.5	-26.5
	MCS3	-27.2	-26.5	-26.4
	MCS5	-27.3	-26.5	-26.1
	MCS7	-28.3	-28.2	-28.1

Transmit Center Frequency Tolerance

11g transmit center frequency tolerance test result:

Channel	CH6
Result(ppm)	0.65
Frequency tolerance	1.57KHz
Pass/Fail	PASS

11n transmit center frequency tolerance test result:

Channel	CH6
Result(ppm)	0.71
Frequency tolerance	1.73KHz
Pass/Fail	PASS

Receiver sensitivity (Unit in dBm)

11b mode: 1RX

mode	Rate	Channel 1	Channel 6	Channel 13
11b	1Mbps	-90	-90	-90
	2Mbps	-90	-90	-91
	5.5Mbps	-89	-89	-88
	11Mbps	-85	-85	-86

11g mode: 1RX

mode	Rate	Channel 1	Channel 6	Channel 13
11g	6Mbps	-90	-90	-90
	9Mbps	-90	-90	-91
	12Mbps	-89	-89	-88
	18Mbps	-85	-85	-86
	24Mbps	-78	-79	-78
	36Mbps	-75	-75	-75
	48Mbps	-71	-71	-71
	54Mbps	-69	-68	-70

11n 20MHz mode: 1RX

mode	Rate	Channel 1	Channel 6	Channel 13
11n 20MHz	MCS0	-85	-85	-85
	MCS1	-82	-82	-82
	MCS2	-80	-80	-80
	MCS3	-77	-77	-77
	MCS4	-73	-74	-74
	MCS5	-69	-70	-69
	MCS6	-68	-68	-68
	MCS7	-66	-66	-66

11n 40MHz mode: 1RX

mode	Rate	Channel 1	Channel 6	Channel 13
11n 40MHz	MCS0	-83	-83	-83
	MCS1	-79	-80	-80
	MCS2	-77	-77	-77
	MCS3	-74	-75	-75
	MCS4	-71	-71	-71
	MCS5	-67	-67	-67
	MCS6	-65	-65	-65
	MCS7	-63	-63	-63

Power Consumption

mode	Status	Power(mW)	Note
OS Windows XP	Link	3.3Vx110=	20M
		3.3Vx120=	40M
	RX	3.3Vx115=	20M
		3.3Vx120=	40M
	TX	3.3Vx150=	20M
		3.3Vx160=	40M
	Power save mode	3.3Vx20=	DTIM=100ms
	Device Disable	3.3Vx25=	
	Radio Off	3.3Vx3=	

Federal Communication Commission Interference Statement

This equipment has been tested and found to comply with the limits for a Class B digital device, pursuant to Part 15 of the FCC Rules. These limits are designed to provide reasonable protection against harmful interference in a residential installation. This equipment generates, uses and can radiate radio frequency energy and, if not installed and used in accordance with the instructions, may cause harmful interference to radio communications. However, there is no guarantee that interference will not occur in a particular installation. If this equipment does cause harmful interference to radio or television reception, which can be determined by turning the equipment off and on, the user is encouraged to try to correct the interference by one of the following measures:

Reorient or relocate the receiving antenna.

Increase the separation between the equipment and receiver.

Connect the equipment into an outlet on a circuit different from that to which the receiver is connected

Consult the dealer or an experienced radio/TV technician for help..

FCC Caution:

Any changes or modifications not expressly approved by the party responsible for compliance could void the user's authority to operate this equipment.

FCC Compliance information

This device complies with Part 15 of the FCC Rules. Operation is subject to the following two conditions: (1) This device may not cause harmful interference, and (2) this device must accept any interference received, including interference that may cause undesired operation.

For product available in the USA market, only channel 1~11 can be operated. Selection of other channels is not possible.

This device and its antenna(s) must not be co-located or operation in conjunction with any other antenna or transmitter.

This device is going to be operated in 2412~2462MHz frequency range, it is restricted in indoor environment only.

FCC Radiation Exposure Statement:

This modular was suitable for a mobile device that is defined as a transmitting device designed to be used in other than fixed locations and to generally be used in such a way that a separation distance of at least 20 centimeters is normally maintained between the transmitter's radiating structure(s) and the body of the user or nearby persons.

This equipment complies with FCC RF radiation exposure limits set forth for an uncontrolled environment. This equipment should be installed and operated with a minimum distance of 20 centimeters between the radiator and your body. This transmitter must not be co-located or operating in conjunction with any other antenna or transmitter.

IMPORTANT NOTE:

This module is intended for OEM integrator. The OEM integrator is still responsible for the FCC compliance requirement of the end product, which integrates this module.

20cm minimum distance has to be able to be maintained between the antenna and the users for the host this module is integrated into. Under such configuration, the FCC radiation exposure limits set forth for an population/uncontrolled environment can be satisfied.

Any changes or modifications not expressly approved by the manufacturer could void the user's authority to operate this equipment.

USERS MANUAL OF THE END PRODUCT:

In the users manual of the end product, the end user has to be informed to keep at least 20cm separation with the antenna while this end product is installed and operated. The end user has to be informed that the FCC radio-frequency exposure guidelines for an uncontrolled environment can be satisfied. The end user has to also be informed that any changes or modifications not expressly approved by the manufacturer could void the user's authority to operate this equipment. If the size of the end product is smaller than 8x10cm, then additional FCC part 15.19 statement is required to be available in the users manual: This device complies with Part 15 of FCC rules. Operation is subject to the following two conditions: (1) this device may not cause harmful interference and (2) this device must accept any interference received,

Label and manual requirements for the End Product

For an end product using the FN-8110M there must be a label containing, at least, the following information.

FCC ID certification number for model : FN-8110M

This device contains FCC ID : OCXFN-811

The label must be affixed on an exterior surface of the end product such that it will be visible upon inspection in compliance with the modular approval guidelines developed by the FCC

Where the **FN-8110M** will be installed in final products larger than 8cm × 10cm following statements has to be placed onto the device .

"Operation is subject to the following two conditions: (1) this device may not cause harmful interference, and (2) this device must accept any interference received, including interference that may cause undesired operation."

Assure compliance

The use of the modular transmitter is only approved to be used inside the specified equipment which compliance with all the instruction was subjected. We assure the compliance of the end product when it is assembled inside the specified equipment.

Caution

Modifications not expressly approved by the party responsible for compliance could void the user's authority to operate the equipment.

Antenna

This device shall only be used with the tested antenna and separate approval is required for all other operating configurations. Antenna gain:1dBi, models:miao,manufacturer: Sanshui technology Co., LTD

RF exposure compliance

The antenna(s) used for this transmitter must not be co-located or operating in conjunction with any other antenna or transmitter.