

Quick Start

AC750 WiFi Range Extenders

Model EX3920



NETGEAR®

Getting Started

The NETGEAR WiFi Range Extenders increase the distance of a WiFi network by boosting the existing WiFi signal and enhancing the overall signal quality over long distances. An extender repeats the signals from an existing WiFi router or access point.

WiFi Range Extenders

Boost the range of your existing WiFi and create a stronger signal in hard-to-reach areas

Existing WiFi

Sometimes your router does not provide the WiFi coverage that you need

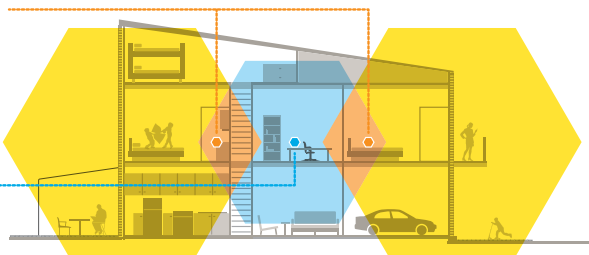

Note: Each extender must connect to your router's WiFi network. Do not connect the extenders to another extender's WiFi network.

Meet Your Extenders

Before you install your extenders, familiarize yourself with their LEDs, buttons, and ports.

Front Panel

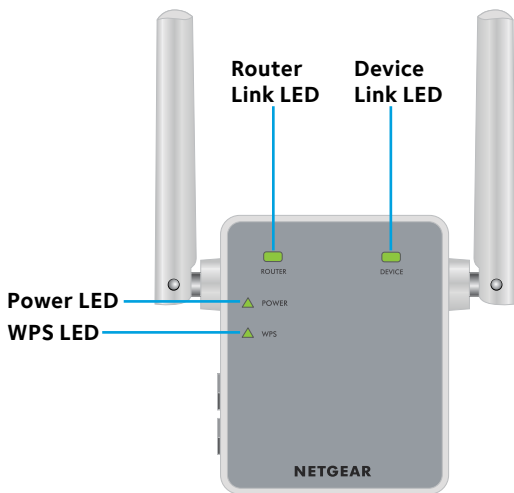

Side Panels

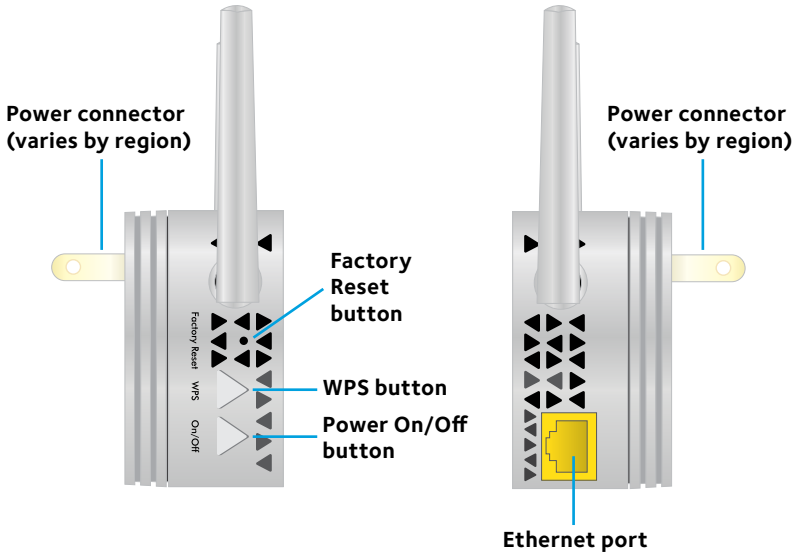

LED Descriptions

Router Link LED



ROUTER

This LED indicates the connection between the extender and the router or access point.

Solid green. Best connection.

Solid amber. Good connection.

Solid red. Poor connection.

Off. No connection.

Device Link LED



DEVICE

This LED indicates the connection between the extender and a computer or WiFi device.

Solid green. Best connection.

Solid amber. Good connection.

Solid red. Poor connection.

Off. No connection.

Power LED



POWER

Solid amber. The extender is booting.

Solid green. The extender is powered on.

Off. The extender is powered off.

WPS LED



WPS

Solid green. WiFi security is enabled (WPA or WPA2).

Blinking green. A WPS connection is being established.

Off. WiFi security is not enabled.

Note: If the Router Link LED or Device Link LED lights amber or red, see *Find the Best Location* on page 11.

Use the Extenders in Extender Mode

Place the extenders, apply power, and connect them to your router's WiFi network.

Place the Extenders and Apply Power

1. Place an extender in the same room as your WiFi router.
Proximity to the WiFi router is required only during the initial setup process.
2. Plug the extender into an electrical outlet.
Wait for the Power LED to light green. If the Power LED does not light, press the **Power On/Off** button on the extender.
3. Repeat Steps 1–2 for the second extender.

Connect to an Existing WiFi Network

To extend the range of your WiFi network, you must connect the extenders to your existing router's WiFi network. You can do this in one of two ways:

- **Connect with WPS.** For more information, see *Connect with WPS* on page 7.
- **Connect with web browser setup.** For more information, see *Connect with Web Browser Setup* on page 9.

Note: Each extender must connect to your router's WiFi network. Do not connect the extenders to another extender's WiFi network.

Connect with WPS

Wi-Fi Protected Setup (WPS) lets you join a secure WiFi network without typing the network name and password.

Note: WPS does not support WEP network security. If you are using WEP security, follow the instructions in *Connect with Web Browser Setup* on page 9.

1. Press the **WPS** button on the side panel of the extender.
The WPS LED blinks.

2. Within two minutes, press the **WPS** button on your router.

The WPS LED on the extender lights solid green, the Router Link LED lights, and the extender connects to your existing WiFi network.

If the Router Link LED does not light, try again. If it still does not light, see *Connect with Web Browser Setup* on page 9.

3. If your WiFi router supports the 5 GHz band, repeat Steps 1 and 2 to connect the extender to the 5 GHz band.

4. Find the new extended WiFi network name on your computer or WiFi device.

The extender creates two new extended WiFi networks. The extender's new WiFi network names are based on your existing WiFi network name, with `_2GEXT` and `_5GEXT` at the end of the name.

For example:

- **Existing WiFi network name.** MyNetworkName
- **New extended WiFi network names.** MyNetworkName_2GEXT and MyNetworkName_5GEXT

5. Connect your computer or WiFi device to the new extended WiFi network.

Use the same WiFi password that you use for your WiFi router.

6. Unplug the extender and move it to a new location closer to the area with a poor WiFi signal.

The location that you choose must be within the range of your existing router's WiFi network.

7. Plug the extender into an electrical outlet.
Wait for the Power LED to light green. If the Power LED does not light, press the **Power On/Off** button on the extender.
8. Use the Router Link LED on the front panel to help you choose a spot where the extender-to-router connection is optimal.
9. Repeat Steps 1–8 to connect the second extender.

Connect with Web Browser Setup

1. Use a WiFi network manager on a computer or WiFi device to find and connect to the NETGEAR_EXT (SSID) WiFi network.
After the connection with the computer or WiFi device is established, the Device Link LED lights.
2. Launch a web browser.
3. Enter **www.mywifiext.net** in the address field of the browser.
The New Extender Setup screen displays.
4. Click the **NEW EXTENDER SETUP** button.
The Extender Setup screen displays.
5. Complete the fields on the Extender Setup screen and click the **NEXT** button.

6. Click the **WIFI RANGE EXTENDER** button.
The extender searches for WiFi networks in your area and displays a list.
7. Select a WiFi network to extend and click the **NEXT** button.
If you do not want to extend both WiFi bands, clear the **2.4GHz WiFi Networks** or the **5GHz WiFi Networks** check box.
Note: If you already installed an extender, do not select the extender's WiFi network.
8. In the **Password (network key)** field, type the existing WiFi network password (also called passphrase or security key) and click the **NEXT** button.
9. Set the network name (SSID) and password for your extender and click the **NEXT** button.
10. Use a WiFi network manager on the computer or WiFi device to connect to the new extended WiFi network.
Repeat this step for all of your computers and WiFi devices.
11. Click the **Continue** button.
A message displays confirming that the extender is connected to the new extended WiFi network.
12. Click the **Next** button.
The Status screen displays.

13. Unplug the extender and move it to a new location closer to the area with a poor WiFi signal.

The location that you choose must be within the range of your existing WiFi router network.

14. Plug the extender into an electrical outlet.

Wait for the Power LED to light green. If the Power LED does not light, press the **Power On/Off** button on the extender.

Use the Router Link LED to help you choose a spot where the extender-to-router connection is optimal.

15. Repeat Steps 1–14 to connect the second extender.

Find the Best Location

If the WiFi signal is weak, the first time you join the extender network, the Router Link LED or Device Link LED lights amber or red. If this happens, adjust the position of the extender:

- If the Router Link LED lights amber or red, move the extender closer to the router.
- If the Device Link LED lights amber or red, move the computer or WiFi device closer to the extender.

Use the Extenders in Access Point Mode

You can use the extenders as WiFi access points, which creates new WiFi hotspots using a wired Ethernet connection.

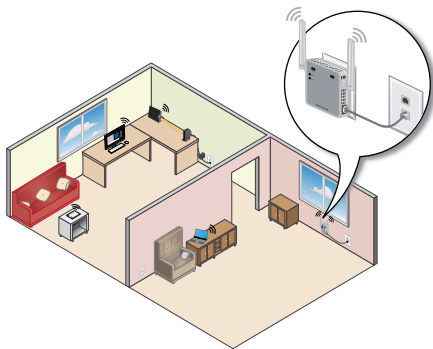

1. Plug an extender into an electrical outlet.
Wait for the Power LED to light green. If the Power LED does not light, press the **Power On/Off** button.
2. Use an Ethernet cable to connect the Ethernet port on the extender to a router Ethernet LAN port or a remote Ethernet LAN jack with LAN access.
The extender joins the LAN and creates a WiFi hotspot.

3. Use a WiFi network manager on a computer or WiFi device to find and connect to the NETGEAR_EXT (SSID) WiFi network.
After the connection with the computer or WiFi device is established, the Device Link LED lights.
4. Launch a web browser and enter **www.mywifiext.net** in the address field.
The New Extender Setup screen displays.
5. Click the **NEW EXTENDER SETUP** button.
The Extender Setup screen displays.
6. Complete the fields on the Extender Setup screen and click the **NEXT** button.
7. Click the **ACCESS POINT** button.
The extender checks for an Internet connection.
8. Set the network name (SSID), security option, and password for each access point network, and click the **NEXT** button.
Your settings are applied and the extender is ready to be used as an access point.
9. Use a WiFi network manager on the computer or WiFi device to connect to the new access point WiFi network.
10. Repeat Steps 1–9 to install the second extender.

Connect an Ethernet-Enabled Device

After the extenders are connected to your existing WiFi network, you can connect wired devices to the extenders using an Ethernet cable. That device can then access your existing network through the WiFi connection.

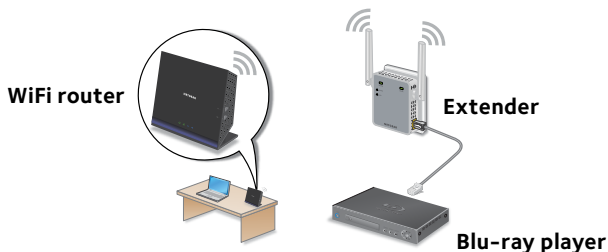

Log In to Access Extender Settings

After installation, you can log in to the extenders to view or change their settings.

1. Use a WiFi network manager on a computer or WiFi device to find and connect to one of the new extended WiFi networks.
After the connection with the computer or WiFi device is established, the Device Link LED lights.
2. Launch a web browser.

3. Enter **www.mywifiext.net** in the address field of the browser.
A login screen displays.
4. Type your email address and password and click the **LOG IN** button.
The Status screen displays.
5. Make any needed changes.

Frequently Asked Questions

You can find more information about your extenders in the user manual, which is available at <http://downloadcenter.netgear.com>.

The web browser setup guide keeps asking me for my network password (passphrase) or security key, and I am sure that I entered the correct password. What can I do?

The extender is probably placed at the borderline of the range covered by the router or access point. For more information, see *Place the Extenders and Apply Power* on page 6.

If you are using WEP security, make sure that you are typing the network password in the correct field.

Can I connect the extender to another extender's WiFi network?

NETGEAR recommends that you do not connect an extender to another extender's WiFi network. For the best WiFi performance and network configuration, connect all extenders to a router.

Can I set up the extenders in extender mode if I connect them to the router or access point with an Ethernet cable?

No. The extenders are designed to connect wirelessly to the router or access point if they are in extender mode. If the extenders are in access point mode, you can connect them to the router or access point with an Ethernet connection. For more information about access point mode, see *Use the Extenders in Access Point Mode* on page 12.

I am connected to NETGEAR_EXT and launched a browser. Why can't I see the web browser setup guide?

Try these troubleshooting steps:

- Make sure that your computer is set up to use DHCP (most are).
- Make sure that the Device Link LED is green and that you are using a valid IP address.
- Relaunch the web browser and type **www.mywifiext.net** in the address field. Type your email address and password and click the **LOG IN** button.

How do I restore the extender to its factory default settings?

1. Use a sharp object such as a pen or paper clip to press and hold the **Factory Reset** button on the extender for at least five seconds until the Power LED lights amber.
2. Release the **Factory Reset** button and wait for the extender to reboot.

The extender resets and returns to the factory default settings.

I forgot my login email address and password. What can I do?

On the login screen, click the **Username & Password Help** link to answer the security questions that you set up during the initial setup.

If you forgot the answers to your security questions, do the following to set up your login credentials again:

1. Restore the extender to its factory default settings.
2. Launch a web browser.
3. Enter **www.mywifiext.net** in the address field of the browser.
The New Extender Setup screen displays.
4. Click the **NEW EXTENDER SETUP** button.
The Extender Setup screen displays.
5. Complete the fields on the Extender Setup screen.

I enabled a wireless MAC filter, wireless access control, or access control list (ACL) on my router. What should I do when installing the extenders?

When the WiFi device connects through the extenders to your router, the MAC address of the WiFi device shown on the router is translated to another MAC address. If your router's MAC filter, wireless access control, or ACL is enabled, the WiFi device connects to the extenders but cannot get an IP address from the extender and cannot access the Internet.

To allow the WiFi device to receive an IP address from the extenders and access the Internet, you must provide the translated MAC address to the router.

1. Log in to your router and disable the MAC filter, wireless access control, or ACL.

For more information about how to disable your router's MAC filter, wireless access control, or ACL, see your router's documentation.

2. Power on the extender and connect all of your WiFi devices to the extender network.
3. Make sure that the Router Link LED remains lit.
4. Log in to your extender:
 - a. Launch a web browser.
 - b. Enter **www.mywifiext.net** in the address field of the browser.
A login screen displays.

- c. Type your email address and password and click the **LOG IN** button.

The Status screen displays.

5. Select **Settings > WiFi Settings**.
6. Scroll down and select **Connected Devices**.

The Connected Devices section displays the MAC addresses and virtual MAC addresses for computers and WiFi devices that are connected to the extender network.

7. Repeat Steps 4–6 for the second extender.
8. On the router, add all of the virtual MAC addresses from your extender to your router's MAC filter table.
9. Enable the router's MAC filter, wireless access control, or ACL.

Support

Thank you for purchasing this NETGEAR product. After installing your device, locate the serial number on the label of your product and use it to register your product at <https://my.netgear.com>. You must register your product before you can use NETGEAR telephone support. NETGEAR recommends registering your product through the NETGEAR website.

For product updates and web support, visit <http://support.netgear.com>.

NETGEAR recommends that you use only the official NETGEAR support resources. You can get the user manual online at <http://downloadcenter.netgear.com> or through a link in the product's user interface.

Trademarks

© NETGEAR, Inc., NETGEAR and the NETGEAR Logo are trademarks of NETGEAR, Inc. Any non-NETGEAR trademarks are used for reference purposes only.

Compliance

For the current EU Declaration of Conformity, visit http://support.netgear.com/app/answers/detail/a_id/11621/.

For regulatory compliance information, visit <http://www.netgear.com/about/regulatory/>.

See the regulatory compliance document before connecting the power supply.



201-19177-01

March 2015

NETGEAR, Inc.

350 East Plumeria Drive
San Jose, CA 95134, USA